



**GOVERNMENT OF INDIA
MINISTRY OF RAILWAYS**

GUIDELINES FOR EARTHWORK IN RAILWAY PROJECTS

**Guideline No. GE: G-1
(including correction slip no. 1)**

July 2003

**Geo-technical Engineering Directorate,
Research Designs and Standards Organisation
Manak Nagar, Lucknow – 11**

FOREWORD

The Railway track system is an important part of the transportation infrastructure of the country. Coupled with economic growth of our great country, the Railways have to carry ever-increasing traffic by augmenting the existing capacities in terms of higher axle loads as well as greater speeds. This calls for a sound track system, both superstructure and substructure.

RDSO has been involved with research and standardization aspects of substructure for the last few decades. Various guidelines have been issued from time to time covering different aspects of track foundation. There have been numerous correction slips added with the experience gained. However, the practice in the field shows wide variations from one railway to the other, some of which may be attributable to lack of clarity on many aspects of geo-technology. Accordingly, a committee of experts was formed to compile the various instructions, correction slips and reiterate some of the neglected aspects of construction/maintenance practices.

I am happy to see that this book containing detailed guidelines for earthwork in Railway Projects draws upon the past experience and developments in other parts of the world in order to pass on the right and adequate knowledge to the field engineers concerned both with construction as well as maintenance aspects. It is particularly heartening to see the right emphasis on quality control by incorporation of the details of field tests and various formats and proforma through which quality can be monitored at different levels.

I am sure the book will be found very useful by all sections of Civil Engineers. Your feedback may be sent directly to Exe. Dir.(GE), RDSO or Exe. Director (P), Railway Board, who will be glad to take care of your doubts and suggestions.

June 2003

Member Engineering
Railway Board, New Delhi.

PREFACE

Performance of a track primarily depends on the soundness of its foundation. To keep maintenance requirements low and have good riding quality, its formation should be adequately designed to cater for envisaged traffic loads and constructed with modern and appropriate techniques. Already large lengths of formations constructed earlier as well as recently, are showing signs of distress under present level of traffic. These lengths are likely to increase manifolds with the introduction of higher axle loads, speeds and enhanced GMT.

Geo-technical Engineering Directorate of RDSO had already issued Guidelines for execution of earthwork in Railway projects in year 1970, which were revised subsequently, in year 1978 and 1987. Guidelines for earthwork in conversion projects were also issued in 1995. Further addition in knowledge and experience in field of geo-technical engineering brought the need for revision and amalgamation of various relevant Guidelines into one. Railway Board asked RDSO to revise existing Guidelines for earthwork in Railway project to avoid duplication of provisions and curtail multiplicity vide Railway Board's letter no. 94/CE-II/MB/6 dated 27.8.2001. A draft revised Guidelines had been prepared and sent to the Railway Board by RDSO. Vide letter no. 94/CE-II/MB/6 dt. 5.12.2001, 12.02.2002 & 15.04.2002, Railway Board nominated a committee of following officers for revision of existing Guidelines:

Name	Designation
Shri V. K. Jain	Chief Engineer (General), Northern Railway Convenor
Shri Pramod Kumar	Executive Director (General), Civil Engg., Railway Board Member
Shri S. K. Raina	Executive Director, Geotechnical Engineering, RDSO Member
Shri Abhay Kumar Mishra	Chief Engineer (Central), Northern Railway Member

On the basis of the discussion held in various meetings of this committee, the final revised Guidelines was prepared. The committee was rendered valuable suggestions and assistance from S/Shri Ashok Kumar Mishra, Director/GE, and S. K. Awasthi, ARE/GE, RDSO during deliberation and preparation of this booklet.

These Guidelines now cover briefly all aspects of design and construction of earthwork in New lines, Doubling, Gauge conversion and Rehabilitation works. This also incorporates all the correction slips already issued till date. These guidelines emphasise on provision of blanket layer of different thickness on formation based on experience and behaviour of different type of subgrades under repetitive loading and recommends mechanical execution of earthwork with emphasis on quality control of earth work. The guidelines has been made more user friendly by incorporating basic design details and standard formats for control of quality etc. It is expected that the revised guidelines will enable Engineers on Indian Railway to achieve awareness and quality in execution of earthworks in Railway formations.

CONTENTS

S. No. No.	Title	Page
1.	Preamble	1
2.	Definitions	1
3.	Soil Exploration & Surveys	2
4.	Design of Railway Formation	7
5.	Materials for construction	14
6.	Execution of Formation Earthwork	15
7.	Quality Control of Earthwork	28
8.	Maintenance of Records	32
9.	Association of RDSO for Quality Assurance in Construction Projects	33
10.	References	33

SKETCHES

- A. Broad gauge track showing the nomenclature of various items
- B. Specification for Blanket Materials
- C. Minimum Recommended Formation Width for Banks/Cuttings
- D. Limits in the Gradation Curves Separating Liquefiable and non-liquefiable soils
- E. Details of Side Drains and Catch water Drains in Cuttings
- F. Scheme for Bank Widening showing Benching and Sandwich Construction
- G. Typical embankment profile for Sandwich construction with cohesive soils
- H. Sampling Patterns for Check of Compaction
- I. Details of Backfill on Bridge Approach

ANNEXURES

- I. Brief Details of Soil Classification
- II. Relevant paras of Engineering Code
- III. Procedure for Slope Stability Analysis
- IV. Field Compaction Trial
- V. Compaction Characteristics of different materials
- VI. Proforma for Maintenance of Records
- VII. Summary of Quality Control Tests
- VIII. Salient Features of Vibratory Rollers
- IX. List of Relevant IS codes
- X. List of Equipments In Field Laboratory

GUIDELINES FOR EARTHWORK IN RAILWAY PROJECTS

1.0 PREAMBLE

Extensive research work has been done to identify the most efficient, economic and suitable design and construction procedure for a sound and trouble-free railway embankment. While most of the work has been done in relation to earth dams, experience with rail-road construction indicates that the provisions of the guidelines issued earlier (for new construction as well as gauge conversion) in 1987 and 1995 need elaboration and updating.

Various studies done on Indian Railways indicate that large lengths of railway formation are of failing type and huge resources are being consumed for maintenance of track in order to ensure the safety of the traffic.

In view of this scenario, it is felt necessary to update various guidelines on the subject and to combine guidelines issued earlier into a single guideline for the benefit of field Engineers.

2.0 DEFINITIONS

For the sake of clarity, a few commonly used terms with their specific meanings are explained in sketch-A, showing cross section of a BG track.

- 2.1 Track Foundation:** Constitutes ballast, blanket and subgrade, which is placed / exist below track structure to transmit load to subsoil.
- 2.2 Ballast:** Crushed stones with desired specifications placed directly below the sleepers.
- 2.3 Sub-ballast:** Sub-ballast is a layer of coarse-grained material provided between blanket/subgrade and ballast and confined to width of ballast section only. However, sub-ballast is not in vogue on Indian Railways. Therefore, its provision has not been considered in these Guidelines.
- 2.4 Blanket:** Blanket is a layer of specified coarse, granular material of designed thickness provided over full width of formation between subgrade and ballast.
- 2.5 Sub-grade:** It is part of embankment/cutting provided above subsoil by borrowed soil of suitable quality upto bottom of blanket/ballast.
- 2.5.1 Cohesive Subgrade:** Subgrade constructed with soils having cohesive behaviour i.e., shear strength is predominantly derived from cohesion of the soil is termed as cohesive subgrade. Normally, soils having particles finer than 75 micron exceeding 12% exhibit cohesive behaviour. As per IS classification, all fine-grained soils and GM, GM-GC, GC, SM, SM-SC & SC types of soils exhibit cohesive behaviour.

Guidelines for Earthwork in Railway Projects

Note: Soil classification in these Guidelines is as per IS: 1498-1970. For ready reference, brief details of soil classification, as per IS: 1498 are given at Annexure-I.

- 2.5.2 Cohesionless Subgrade:** Subgrade constructed with cohesionless, coarse-grained soils i.e., shear strength is predominantly derived from internal friction of the soil are termed as cohesionless subgrade. Normally, soils having particles finer than 75 micron less than 5% exhibit cohesionless behaviour. As per IS Classification, GW, GP, SW & SP types of soils fall in this category.
- 2.5.3** Other types of soils, which have soil particles finer than 75 micron between 5 to 12%, need detail study for ascertaining their behaviour.
- 2.6 Dispersive Soil:** Dispersive clayey soils are those, which normally deflocculate when exposed to water of low salt content. Generally, dispersive clayey soils are highly erosive and have high shrink and swell potential. These soils can be identified by Crumb, Double Hydrometer, Pin Hole and Chemical Tests.
- 2.7 Formation Top:** Boundary between ballast and top of blanket or subgrade (where blanket layer is not provided).
- 2.8 Cess:** It is part of top of formation from toe of ballast to edge of formation.
- 2.9 Formation:** It is a general term referring to the whole of blanket, sub-grade and sub-soil.
- 2.10 Sub-soil:** Soil of natural ground below subgrade.
- 2.11 Unstable Formation:** It is yielding formation with non-terminating settlement including slope failure, which require excessive maintenance efforts.

3.0 SOIL EXPLORATION & SURVEY

- 3.1** Objectives of constructing a stable formation can only be achieved if soil exploration, as envisaged in Engineering Code Paras E--409, 425 and 528, is undertaken in right earnest and precautions are taken to design bank & cutting against likely causes which could render it troublesome during service. The above referred paras of Engineering Code have been reproduced in Annexure-II.
- 3.2** Adequate provision for soil surveys & explorations at different stages, as per requirements of the terrain, should be made in the project estimates to cover the cost for this activity.
- 3.3 Objectives of Soil Exploration:**

Main objectives of soil survey and exploration work are:

- a) to determine soil type with a view to identify their suitability for earthwork in formation and to design the foundation for other structures.

Guidelines for Earthwork in Railway Projects

- b) to avoid known troublesome spots, unstable hill sides, swampy areas, soft rock areas, peat lands, etc.
- c) to determine method of handling and compaction of subgrade.
- d) to identify suitable alignment for embankment and cutting from stability, safety, economy in construction and maintenance considerations.
- e) to identify suitable borrow area for desired quality and quantity of subgrade and blanket material.
- f) to determine depth of various strata of soil and bed rock level.
- g) to determine ground water table position and its seasonal variation and general hydrology of the area such as flood plains, river streams, etc.
- h) to determine behaviour of existing track or road structure nature and causes of geo-technical problems in them, if any.

3.4 Soil survey and exploration for construction projects should be carried out in following three stages:

3.4.1 Soil Investigation during Reconnaissance Survey

- a) The main objective of soil survey during Reconnaissance is to collect maximum surface and sub-surface information without drilling exploratory boring/ test pits to avoid obviously weak locations such as unstable hill sides, talus formation, swampy areas, peat grounds, very soft rocks or highly weathered rocks, etc.
- b) At reconnaissance stage, available data from geological and topological maps and other soil surveys done in past, existing soil profiles in nearby cuts, quarries are scrutinized. Water table is recorded from local observation and inquiry. The involved soils are classified by visual examination and if necessary, few field/ laboratory tests are conducted for this purpose.
- c) Survey reports available from other Departments/Agencies such as Geological Survey of India, Ministry of Road Transport and Highways, Central Board of Irrigation and Power, CPWD, State Irrigation, PWD, etc. can be acquired to obtain information on the accessibility, geology and soils, subsurface information, etc.
- d) Areas of prospective borrow soil and blanket material should also be surveyed to give idea of quality and quantity of materials to be used for construction of Railway embankment.
- e) Above collection of data should be incorporated in the Feasibility Report required to be submitted as per para 576 and 555 in chapter of Project Engineering under heading of formation (para 528 of Engineering Code).
- f) The data and information collected during survey should be presented in suitable format such as graphs, bar chart or in tabular or statement form.

3.4.2 Soil Investigation during Preliminary Survey

- a) Primary objective of preliminary exploration is to obtain sufficient subsurface data to permit selection of the type, location and principal dimensions of all major structure and estimation of earthwork and design of formation. The scope of preliminary survey is restricted to determination of depths, thickness and composition of each soil stratum, location of rock and ground water and also to obtain appropriate information regarding strength and compressibility characteristics of various soil strata.
- b) As stated in Para E-409 of Engineering Code, the field work in Preliminary Survey includes a compass traverse along one or more routes with transverse and longitudinal levels to prepare a L- section of routes proposed. This fieldwork shall also cover a soil survey by sampling at suitable intervals in order to obtain a fair idea of the soil classification and characteristics of soils on proposed routes. Testing of disturbed soil samples is usually adequate, however core drilling will be necessary in rocks. This will help in determining thickness of blanket layer on different sections and total quantity of blanket material to be required.
- c) Exploratory boring with hand/ auger samplers and soil sampling should be undertaken along the alignment and soil samples also should be collected from borrow pit area, at an interval of 500 meter or at closer interval, wherever change of soil strata occurs. The boring should be done upto 1.5 to 2.0 m depth below existing ground level. In case of high embankment and problematic substrata, the boring should be taken down to a depth equal to twice the height of embankment. Samples should be collected from each stratum found in each boring.
- d) Bore logs are prepared based on laboratory test results of disturbed samples obtained by auguring or split spoon sampler. Particle size distribution, soil classification and index properties of the soils are determined from laboratory tests.
- e) In case of soft clays and sensitive clays, in-situ vane shear tests should be conducted to determine its shear strength and depth of underlying compressible clay layer. Undisturbed tube samples should also be collected to know actual moisture content, natural dry density and shear and consolidation parameters of the soil.
- f) Geo-physical investigations for bedrock profile, sub-surface strata and soil properties are required to be carried out for foundation of major structures such as bridges. Methods such as Seismic Refraction Method (IS: 1892-1979), Standard Penetration Test (IS: 2131- 1981), Dynamic Cone Penetration Test (IS: 4968-1974) etc, will be required to be carried out to ascertain constituents of substrata and their properties and design foundation of such structures. In alluvial strata, deep auger boring upto 6m may be deployed for subsurface exploration and sampling.
- g) The data and information collected during survey should be presented in suitable format such as graphs, bar chart or in tabular or statement form.

3.4.3 Soil Investigation during Final Location Survey

- a) During Final Location survey, detailed investigations are done at locations where important structures viz. high bank, deep cuttings, major bridges etc. are to be located and where weak sub-soil, swampy ground, marshy land exist. Undisturbed soil samples with the help of deep auger sampler or Split spoon samplers are collected for conducting detailed tests viz. shear strength tests & consolidation test to design safe and economical structure and predict settlements. However, if some tests during preliminary survey are deficient, the same should also be covered.
- b) Assistance may be taken from Geologist, in case of rocky strata, known unstable hill slopes, earthquake prone area and geological fault.
- c) Detailed subsoil exploration is necessary to check stability of structures against failure and to predict anticipated settlement. Bores are made along alignment normally at 200 m to 300m apart in case of uniform type of soil and closely spaced in critical zones. Soil samples within the boreholes are obtained at every change of stratum and interval not exceeding 1.5 m. In case of sandy and gravely soils, Standard Penetration Test may be adequate, as taking out samples in these type of strata is difficult.
- d) Besides classification tests, soil samples should be tested for shear strength and consolidation properties. In case of very soft clays, vane shear test should be conducted for each boring site. Free swell index test should also be carried out in case of expansive soil and organic contents of soil should be determined if soil is suspected to be having large organic contents.
- e) Sources of blanket material of specified quality and its availability around project site needs to be located to assess its realistic costs for inclusion in project estimates. The source identification should cover various logistics involved in its utilization.
- f) The data and information collected during survey should be presented in suitable format such as graphs, bar chart or in tabular or statement form.

3.5 Soil Survey & Exploration for Conversion, Doubling & Rehabilitation Work

For these projects, additional informations required will be as follows:

- 3.5.1** A statement listing out problematic stretches on existing track should be prepared/obtained after scrutiny of gang charts for identifying locations requiring frequent attentions, having unsatisfactory TRC results, past history of stretches having failure like slips, subsidence, pre-mature ballast recoupmnt, ballast penetration etc
- 3.5.2** Failure of existing formation is accompanied by signs of distress/instability. The identified and suspected locations shall be subjected to detailed examination as per symptoms of failures. Recommended scheme of soil exploration and testing are as under:

Guidelines for Earthwork in Railway Projects

S. No	Symptoms	Type of failure	Recommended Scheme for soil exploration and data collection	Soil testing
1	2	3	4	5
1	<ul style="list-style-type: none"> i) Bank settlement - loss of longitudinal profile ii) Heaving of soil beyond toe iii) Leaning of telegraph posts, trees , etc. on the bank and at the toe 	Base failure	<ul style="list-style-type: none"> i) Recording of bank profiles and ballast profile in x-section ii)Undisturbed sampling iii) Field tests- Vane shear DCP/SPT 	<ul style="list-style-type: none"> i) Classification tests ii)Consolidation tests iii) Natural moisture content and Natural dry density tests. iv) Peak and residual shear strength tests
2	<ul style="list-style-type: none"> i) Flattening of Bank/slope ii) Bulging of slope surface. iii) Longitudinal cracks on cess/slopes iv) Leaning of OHE masts 	Slope failure	<ul style="list-style-type: none"> i) Recording of bank profile and x-section of ballast profile. ii) Survey and recording of surface cracks iii)Undisturbed sampling 	<ul style="list-style-type: none"> i) Classification and swell tests ii) Peak and Residual Shear strength tests iii) Natural moisture content and Natural dry density tests.
3	<ul style="list-style-type: none"> i) Soil heaving on cess and on slopes ii) Ballast penetration exceeding 30 cm below formation iii) Excessive – cross level variations 	Subgrade failure (by shear)	<ul style="list-style-type: none"> i) Recording of bank and ballast penetration profiles inside subgrade ii) Collection of data <ul style="list-style-type: none"> a) Track geometry variations b) Excessive maintenance inputs c) Quantum of ballast recoupment d) Speed restrictions imposed iii) Undisturbed soil samples below the ballast penetration 	<ul style="list-style-type: none"> i) Classification and swell tests ii) Shear strength tests iii) Natural Moisture content and Natural Dry Density tests
4	<ul style="list-style-type: none"> i) Fouling of ballast with subgrade fines ii) Ballast penetration below formation – 30 cm or less iii) Impaired drainage iv) Excessive cross level variations in Mansoon 	Subgrade failure (by mud pumping)	<ul style="list-style-type: none"> i) Recording of bank profile and ballast penetration inside subgrade ii) Collection of data - <ul style="list-style-type: none"> a) Track geometry variations b) Excessive maintenance inputs 	<ul style="list-style-type: none"> i) Classification and swell tests ii) Shear tests iii) Natural Moisture Content and Natural Dry Density tests

Guidelines for Earthwork in Railway Projects

	v) Hard running during summer		c) Speed restrictions imposed iii) Undisturbed soil samples from below the ballast penetration	
5	i) Reduced cess & Denuded slopes- loss of soil/absence of vegetation. ii) Formation of rills/ gullies and pot holes on slopes & on cess	Erosion failure of slopes leading to ballast penetration and slope failure	i) Recording of bank profile ii) Disturbed soil samples	i) Classification tests ii) Field crumb test for soil dispersivity iii) Pin hole test iv) Double hydrometer tests v) Natural Moisture Content and Natural Dry Density tests
6	i) Cut slope failures ii) Choked side drains iii) Seepage of water iv) Saturated subgrade	Failure of Cuttings	i) Recording of profile side slope, longitudinal drain sections, HFL and Ground water table	i) Classification of soils ii) Cross-section and Ballast penetration iii) Natural Moisture Content and Natural Dry Density tests iv) Lab. Shear tests

Notes: a) In practice generally more than one type of failure is encountered.
b) Recommended scheme and soil tests are for general guidance.

3.5.3 Frequency of soil sampling shall depend on the extent and type of problems in the troublesome stretches. However, samples should be taken at 500m intervals for determination of natural dry density and soil type only where no formation problem is reported.

3.5.4 In order to ensure proper bonding of earthwork and soil compatibility behaviour of old and new earthwork, samples of soils from mid-slope of existing bank at about 1 m depth and 500m length or closer intervals should be collected and tested for particle size, natural moisture content, natural dry density and consistency limits.

4.0 DESIGN OF RAILWAY FORMATION

4.1 In order to construct a formation that gives trouble free service under the most adverse conditions of loading, maintenance, and weather, it is necessary that:

Guidelines for Earthwork in Railway Projects

- (i) Sub-grade in bank or cutting is structurally sound so as not to fail in shear strength under its own load and live loads; and
- (ii) Secondly, any settlement due to compaction and consolidation in sub-grade and subsoil should be within the permissible limits.

4.2 Various Aspects of Designing a Sub-Grade & Subsoil

Subgrade should be designed to be safe against shear failure and large deformations. Adequacy of subsoil against shear strength and settlement should also be examined.

4.2.1 Deficient Shear Strength of Sub-Grade &/or Sub-Soil leads to:

- (a) Bearing capacity failure of sub-grade, resulting into cress and crib heave. Deep ballast pockets are formed as a result of such failures. Inadequate cress width is also responsible for initiation and enhancement of bearing capacity failure of subgrade.
- (b) Interpenetration failure or mud pumping failure, resulting into vitiation of clean ballast cushion, and
- (c) Slope failure, if factor of safety against slope stability is not adequate.

Therefore, subgrade/subsoil should be designed to ensure not to allow any shear failure.

4.2.2 Large Deformation without Shear Strength Failures of soil can be due to:

- a) Poor compaction during construction and consolidation (primary and secondary) of subgrade and/or sub-soil; and
- b) Settlement and heave due to shrinking and swelling characteristics of subgrade and/or sub-soil. The swelling and shrinkage characteristics of sub-soil shall be significant in cases where bank height is less than 1m or it is in cutting.

These aspects should be taken into account at the time of construction to avoid large settlement causing maintenance problems and leading to formation failure.

4.2.3 Top Width of Formation:

- (a) It should be adequate enough to accommodate track laid with concrete sleepers and standard ballast section and have minimum 900mm cress width on either side. It should be regulated in accordance with extant instructions of Railway Board. A typical cross section is given in sketch -C.
- (b) **Additional Width** of formation will have to be provided to cater for increase in extra ballast on out side of curves and extra clearance required on double line on account of super-elevation etc.

4.2.4 Adequate Drainage must be ensured for the worst in service conditions. The top of formation should have cross slope of 1 in 30 from centre of track towards both

Guidelines for Earthwork in Railway Projects

sides for single line and from one end towards cess /drain side (single slope) in multiple lines. Further elaboration on drainage is given in para 6.5.

- 4.2.5 The design should provide for a suitable and cost-effective **erosion control** system considering soil matrix, topography and hydrological conditions. Further elaborations have been given in para 6.6.
- 4.2.6 It will be necessary to keep borrow **pits** sufficiently away from the toe of the embankments to prevent base failures due to lateral escapement of the soil. The distance of borrow pit from the bank will have to be decided in each case on its merits. Existing borrow pits, close to toe of bank may be filled or its depth should be taken into account in analysing slope stability of the bank.
- 4.2.7 In the case of embankments / cuttings in **highly cohesive clayey soils**, special treatment may be necessary to ensure a stable formation. Such measures will have to be determined after thorough investigation and study of the soil properties.
- 4.2.8 Special investigation will also be necessary in regard to high fill construction on swampy ground or marshy lands and deep cuttings.
- 4.2.9 In case of all new construction, **minimum height of embankment** should not be less than **one meter** to ensure proper drainage, avoid organic matters and trespassing .
- 4.2.10 Soils prone to **liquefaction** falling in gradation zone as per sketch-D. and having coefficient of uniformity, $C_u < 2$ should be adequately designed to take care of this.

4.3 Provision of Blanket Layer – Design of Thickness and Selection of Material:

To avoid failure of track formation due to inadequate bearing capacity and to safeguard against swelling and shrinking, adequate blanket thickness must be provided in all cases at the time of construction of new lines, permanent diversions, raising of formation, in cuttings etc. or while rehabilitating a failing track formation.

4.3.1 Need for Provision of Blanket Layer & its Functions:

- a) It reduces traffic-induced stresses to a tolerable limit on the top of subgrade, thereby, prevents subgrade failures under adverse critical conditions of rainfall, drainage, track maintenance and traffic loadings.
- b) It prevents penetration of ballast into the subgrade and also prevents upward migration of fine particles from subgrade into the ballast under adverse critical conditions during service.
- c) Its absence or inadequate thickness results in yielding formation and instability. This necessitates high maintenance inputs and leads to increased cost of maintenance. Moreover, crippling speed restrictions may have to be imposed, which adversely affect the throughput.

Guidelines for Earthwork in Railway Projects

- d) Its absence may result in bearing capacity as well as progressive shear failure of subgrade soil, thereby endangering safety of running traffic.
- e) It restricts plastic deformation of subgrade caused due to cyclic stresses induced by moving loads.
- f) It results in increased track modulus and thereby reduces track deformations. Consequently, due to reduction in dynamic augment, stresses in rails as well as sleepers are reduced.
- g) It facilitates drainage of surface water and reduces moisture variations in subgrade, thereby reducing track maintenance problems.
- h) It prevents mud pumping by separating the ballast and subgrade soil. Thus, accumulation of negative pore water pressure in the soil mass is avoided which is responsible for mud pumping.
- i) It ensures that the induced stress in subgrade are below the threshold stress of subgrade soil.
- j) It ensures dissipation of excess pore water pressure developed in subgrade on account of cyclic loading and leads to increase in shear strength of subgrade soil.
- k) It obviates the need for formation rehabilitation work under running traffic at prohibitive cost.
- l) It leads to enhanced performance of subgrade as subgrade can serve designed functions more efficiently and effectively.

The quality and depth of blanket material, as specified in these Guidelines, would carry out the above functions satisfactorily under Indian conditions.

4.3.2 Depth of Blanket Layer:

Depth of blanket layer of specified material depends primarily on type of subgrade soil and axle load of the traffic.

4.3.2.1 Depth of blanket to be provided for axle loads upto 22.5t for different types of subgrade soils (minimum top one meter thickness) has been given as under. In case more than one type of soil exists in top one meter then soil requiring higher thickness of blanket will govern.

Note: Symbols used below for classification of soil at top of sub-grades for deciding blanket depth is as per IS Classification given in IS:1498. For details, refer Annexure - I.

- a) Following soils shall not need blanket:
 - Rocky beds except those, which are very susceptible to weathering e.g. rocks consisting of shales and other soft rocks, which become muddy after coming into contact with water.
 - Well graded Gravel (GW)
 - Well graded Sand (SW)
 - Soils conforming to specifications of blanket material.

Guidelines for Earthwork in Railway Projects

Note: Soils having grain size curve lying on the right side of the enveloping curves for blanket material like cobbles and boulders may/may not need blanket. In such cases, need of blanket and, its design should be done in consultation with RDSO.

- b) Following soils shall need minimum 45cm thick Blanket:
- Poorly graded Gravel (GP) having Uniformity Coefficient more than 2.
 - Poorly grade Sand (SP) having Uniformity Coefficient more than 2.
 - Silty Gravel (GM)
 - Silty Gravel – Clayey Gravel (GM – GC).
- c) Following soils shall need minimum 60cm thick Blanket:
- Clayey Gravel (GC)
 - Silty Sand (SM)
 - Clayey Sand (SC)
 - Clayey Silty sand (SM-SC)

Note: The thickness of blanket on above type of soils shall be increased to 1m, if the plasticity index exceeds 7.

- d) Following types of soils shall need minimum 1m thick Blanket :
- Silt with low plasticity (ML)
 - Silty clay of low plasticity (ML-CL)
 - Clay of low plasticity (CL)
 - Silt of medium plasticity (MI)
 - Clay of medium plasticity (CI)
 - Rocks which are very susceptible to weathering

4.3.2.2 Soils having fines passing 75 micron sieve between 5 & 12% i.e. for soils with dual symbol e.g., GP-GC, SW-SM, etc., thickness of blanket should be provided as per soil of second symbol (of dual symbol) as per para 4.3.2.1 . For example, if the soil of the subgrade over which the blanket is to be provided is classified as GP - GC then blanket depth for GC type of soil i.e. 60 cm as per para 4.3.2.1 (c) is to be provided.

4.3.2.3 Use of geo-synthetics can be considered at places where it is economical to use in combination with blanket as it reduces the requirement of thickness of blanket. It may be particularly useful in cases of rehabilitation of existing unstable formation and in new construction where availability of blanket material is scarce. Use and selection of geo-synthetics should be done in consultation with RDSO.

4.3.2.4 For other types of soil required to be used in subgrade not covered by above clauses, Railways may approach RDSO for getting guidance on deciding blanket thickness depth.

Guidelines for Earthwork in Railway Projects

4.3.2.5 For heavier axle load traffic above 22.5t and upto 25t & above 25t upto 30t, additional blanket thickness of 30cm & 45cm respectively, over and above as given in para 4.3.2.1 of superior quality material, shown as upper blanket layer in sketch "B", should be provided.

4.3.3 Blanket in new lines in light traffic route:

Blanket ensures an important function of reducing induced stresses to acceptable value at top of subgrade. In cohesive subgrades even 100 cycles of repeated load in excess of threshold strength (permissible strength) of subgrade soil will cause failure of formation resulting into large plastic deformations. Therefore, blanket of adequate depth should be provided even for predominantly passenger lines with light traffic.

4.3.4 Specifications of Blanket Material:

4.3.4.1 Blanket material should generally conform to following specifications:

- a) It should be coarse, granular and well graded.
- b) Skip graded material is not permitted.
- c) Non -plastic fines (particles of size less than 75 micron) are limited maximum to 12%, whereas plastic fines are limited maximum to 5%.
- d) The blanket material should have particle size distribution curve more or less within the enveloping curves shown in sketch -B. The material should be well graded with C_u and C_c as under:
Uniformity coefficient, $C_u = D_{60}/D_{10} > 4$ (preferably > 7)
Coefficient of curvature, $C_c = (D_{30})^2 / D_{60} \times D_{10}$ should be within 1 and 3.
- e) The material for upper blanket layer shall be well-graded sandy gravel or crushed rock within the enveloping curves for upper blanket layer as shown in sketch -B.

4.3.4.2 Gradation size analysis and percent fines of blanket material should be determined using wet sieve analysis as per procedure of IS: 2720 (Part IV) - 1985.

4.3.5 Selection of Blanket Material:

- a) Proper survey of area close to projects needs to be carried out to identify suitable sources of blanket material required for the project. Aim of such source identification survey is to use naturally available material, which is cheap and conforms to the specifications laid down.
- b) Blanket material could also be obtained by proper blending of two or more soils. Before approving such sources, trials for blending to judge the final product, needs to be done. Detail methodology of blending to be adopted to produce large quantity of blanket material with consistent quality, needs also to be laid down in advance.

Guidelines for Earthwork in Railway Projects

- c) Quarry dust or material specifically manufactured through crushers using boulders, rocks, etc. as raw material, conforming to the blanket material specification could also be used as blanketing material.
- d) In rare cases, where after studies/trials & survey, blanket material has minor variation from the laid down specifications, RDSO's guidance could be sought after giving details of trials/studies conducted along with justification and details of soil used for subgrade over which blanket is proposed to be laid.

4.4 Design of Side Slope of Embankment:

4.4.1 Slope stability analysis should be carried out to design stable slopes for the embankment. Usually, slopes of 2:1 of embankment upto height of 6.0 m would be safe for most of the soils. However, this analysis has to be carried out in detail for any height of embankment in following situations:

- a) When subsoil is soft, compressible & marshy type for any depth.
- b) When subgrade soil (fill material) has very low value of cohesion ' C ' such that $C/\gamma H$ (where H is height of embankment and γ is bulk density of soil) is negligible, i.e., in range of 0.01 or so.
- c) When highest water table is within $1.5xH$ (H is the height of embankment), below ground level, then submerged unit weight of soil below water level should be taken.

4.4.2 In cutting slope, softening of soil occurs with the passage of time, and therefore, long term stability is the most critical, and should be taken into consideration while designing the cuttings.

4.4.3 Detailed slope stability analysis should be carried out as per procedure laid down in Annexure-III, wherein a typical worked out example of slope stability analysis is also given for guidance. This procedure would be applicable for most of the cases. However, in certain situations, further detailed analysis may be required due to the site conditions, the same may be got done by an expert consultant or matter may be referred to RDSO.

4.4.4 Slope stability analysis may also be carried out using standard computer programme/software especially made for this purpose. However, the efficacy of the software used should have approval/clearance of RDSO.

4.5 Rehabilitation of Existing Unstable Formations

Existing track foundations, which have failed during service, need special investigations as per para 3.3 and relevant paras of IRPWM. Necessary details should be collected and appropriate rehabilitation scheme should be developed in consultation with RDSO, if required. In general, following points may be kept in view while planning for rehabilitation:

Guidelines for Earthwork in Railway Projects

- a) In developing rehabilitation scheme, stretches having similar soil characteristics and embankment performance should also be included simultaneously.
- b) Cause(s) of instability of formation should be analysed and accordingly rehabilitation measures formulated. There may be requirement of reprofiling of slope along with laying of blanket.
- c) In consultation with RDSO, Geosynthetics may also be used along with laying of blanket, to reduce thickness of blanket if found cost effective.
- d) Method of laying of blanket should be appropriate depending upon techno-economical conditions and site requirements.

5.0 MATERIALS FOR CONSTRUCTION:

Construction of embankment is to be carried out normally with soil available in nearby area with proper design of slope and desired bearing capacity. However, there are some soils, which are not normally suitable to be used in construction of new lines as detailed below:

5.1 Unsuitable Soils for Construction:

5.1.1 Soils to be normally avoided are :

- a) Organic clays, organic silts, peat, chalks, dispersive soils, poorly graded gravel and sand with uniformity coefficient less than 2,
- b) Clays and silts of high plasticity (CH & MH) in top 3m of embankment.

5.1.2 Some typical situations, as given below, may arise when in construction of formation such unsuitable types of soils (para 5.1.1) are not possible to be avoided for economical or any other reason, then Railway may consult RDSO to decide special investigations and other measures to formulate suitable scheme of construction.

- a) Cuttings passing through unsuitable soils (para 5.1.1), shales and soft rocks which become muddy after coming into contact with water,
- b) Construction of embankment on subsoil of unsuitable types of soils.
- c) Use of CH & MH type of soils even in top 3m of embankment.

5.2 Use of Mixed Types Soils:

5.2.1 Different types of fill materials, if used, should be deposited in such a way that all parts of the site receive roughly equal amount of a given material in roughly the same sequence to get approximate homogeneous character of sub-grade.

5.2.2 In situations where soils for construction of embankment consist of cobbles, boulders, rock or waste fragments etc., largest size of material should normally not be greater than $2/3^{\text{rd}}$ of the loose layer thickness. However, it should be ensured that after every one to three meter of such construction, a 30 cm layer of properly compacted soil (other than soil as given in para 5.1) be provided. A detail slope stability analysis also needs to be carried out to ensure stability of such embankments.

Guidelines for Earthwork in Railway Projects

5.2.3 In case cobbles, boulders, etc. i.e., rock materials of bigger size than $2/3^{\text{rd}}$ of the loose layer thickness are only in small quantity, these may be placed on toe of the embankment instead of using as subgrade material.

6.0 EXECUTION OF FORMATION EARTHWORK

Before taking up of actual execution of work, detailed drawings need to be prepared for the entire length of the project to give alignment, formation levels, formation width at ground level, cross sections of catch water drains & side drains, cross section & levels of subgrade, blanket levels, etc. to facilitate smooth execution at site. Execution of work has to be carried out in systematic manner so as to construct formations of satisfactory quality which would give trouble free service. The activities and adoption of good practices involved in execution of earthwork are covered under following headings:-

- a) Preliminary works
- b) General aspects
- c) Compaction of earth work
- d) Placement of Back-Fills on Bridge Approaches and Similar Locations
- e) Drainage Arrangement in Bank/Cutting
- f) Erosion control of slopes on banks & cuttings
- g) Other aspects

6.1 Preliminary Works:

6.1.1 Preparation of Natural Ground:

Preparation of natural ground surface may be carried out as follows:

6.1.1.1 Site clearances: Full formation width at ground level plus additional extra width of 1 m on both sides should be cleared of all obstructions viz. vegetation, trees, bushes, building, fences, abandoned structures etc. and thereafter it should be dressed and leveled. Depressions if any, should be filled with suitable soil duly compacted. Finally, leveled surface should be properly compacted by mechanical means to get leveled and uniform ground surface.

6.1.1.2 When Bank is Constructed On Ground Having Steep Slope then the ground surface should be suitably benched so that new material of bank gets well bonded with the existing ground surface.

6.1.2 Setting out of Construction Limits:

Centreline of the alignment (@ 200 m c/c or so) and full construction width should be demarcated with reference pegs/dug belling about 90 cm away from proposed toe of the bank. Care should be taken not to disturbed the pegs during construction. Pegs should be preferably painted for identification.

Guidelines for Earthwork in Railway Projects

6.1.3 Selection of Borrow Area: -

- a) Borrow area should be selected sufficiently away from the alignment, as far as possible at the extreme of Railway land but normally not less than 3 m plus height of the embankment to prevent base failure due to lateral escapement of the soil.
- b) Borrow area should be selected for soil suitable to be used in construction.

6.1.4 Selection of Fill Material:

- a) Except for unsuitable soils as explained in para 5.1, any type of locally available soil can be used as a construction material. OMC & MDD of the selected fill material should be tested in the laboratory as per laid down frequency.
- b) Use of material should be planned in such a way that soil with higher percentage of coarse-grained particle is placed on the upper layers of the embankment.

6.2 General Aspects:

6.2.1 A field trial for compaction on a test section shall be conducted on fill material to assess the optimum thickness of layer and optimum number of passes for the type of roller planned to be used to arrive at desired density. Procedure for field compaction trials is given in Annexure - IV, for guidance.

6.2.2 If the soil has less than required moisture content, necessary amount of water shall be added to it either in borrow pits or after the soil has been spread loosely on the embankment. Addition of water may be done through flooding or irrigating the borrow areas or sprinkling the water on the embankment through a truck mounted water tank sprinkling system. Use of hose pipe for water need to be avoided.

6.2.3 If the soil is too wet, it shall be allowed to dry till the moisture content reaches to acceptable level required for the compaction.

6.2.4 Placement moisture content of soil should be decided based on the field trial and site conditions. The objective should be to compact near OMC to achieve uniform compaction with specified density in most efficient manner.

6.2.5 Clods or hard lumps of soil of borrow area shall be broken to 75 mm or lesser size before placing on embankment.

6.2.6 Each layer should be compacted with recommended type of roller upto required level of compaction, commencing from the sides, before putting next upper layer.

6.3 Compaction of Earth Work:

Performance of the embankment would depend to large extent on the quality of compaction done during execution. Need to ensure proper compaction & precautions/ guidelines for this have been given as follows:

6.3.1 Advantages of Compaction:

6.3.1.1 Compaction is the process of increasing the density of soil by mechanical means by packing the soil particles closer together with reduction of air voids and to obtain a homogeneous soil mass having improved soil properties. Compaction brings many desirable changes in the soil properties as follows:

- a) Helps soils to acquire increase in strength in both bearing resistance and shear strength.
- b) Reduces compressibility, thus minimising uneven settlement during service.
- c) Increases density and reduces permeability, thereby reducing susceptibility to change in moisture content.
- d) Reduction in erodability.
- e) Results in homogenous uniform soil mass of known properties.
- f) Reduction in frost susceptibility in cold regions

6.3.1.2 However, while compaction of earthwork is a necessary condition to achieve a stable formation, it does not help in checking against the following causes which needs to be taken care during the design of bank or cutting :

- (i) Excessive creep or slipping of slopes .
- (ii) Swelling and shrinkage characteristic of soils due to variation in moisture content because physio-chemical properties of a soil do not change on compaction.
- (iii) Mud pumping at ballast - soil interface.
- (iv) Settlements due to consolidation of bank and subsoil that can occur even for a few years after construction of the bank.

6.3.2 Factors Affecting Compaction in the Field:

Compaction of a particular soil is affected by moisture content, compacting effort, type of roller etc as explained below:

- (a) **Compacting Effort:** In modern construction projects, heavy compaction machinery are deployed to provide compaction energy. Types of machinery required are decided based on type of soil to be compacted. The method of compaction is primarily of four types viz a viz. kneading compaction, static compaction, dynamic or impact compaction and vibratory compaction. Different type of action is effective in different type of soils such as for cohesive soils, Sheepsfoot rollers or pneumatic rollers provide the kneading action. Silty soil can be effectively compacted by Sheepsfoot roller/pneumatic roller or smooth wheel roller. For compacting sandy and gravelly soil, vibratory rollers are most effective. If granular soil have some fines both smooth wheeled and pneumatic rollers can be used.
- (b) **Moisture Control:** Proper control of moisture content in soil is necessary for achieving desired density. Maximum density with minimum compacting effort can be achieved by compaction of soil near its OMC (Optimum Moisture

Guidelines for Earthwork in Railway Projects

Content). If natural moisture content of the soil is less than the OMC, calculated amount of water should be added with sprinkler attached to water tanker and mixed with soil by motor grader for uniform moisture content. When soil is too wet it is required to be dried by aeration to reach up to OMC.

- (c) **Soil Type:** Type of soil has a great influence on its compaction characteristics. Normally, heavy clays, clays and silts offer higher resistance to compaction, whereas, sandy soils and coarse grained or gravelly soils are amenable for easy compaction. Coarse-grained soils yield higher densities in comparison to clay. A well-graded soil can be compacted to higher density.
- (d) **Thickness of Layer:** Suitable thickness of soil of each layer is necessary to achieve uniform compaction. Layer thickness depends upon type of soil involved and type of roller its weight and contact pressure of its drums. Normally, 200 – 300 mm layer thickness is optimum in the field for achieving homogenous compaction.
- (e) **Number of Passes:** Density of soil will increase with the number of passes of roller but after optimum number of passes, further increase in density is insignificant for additional number of passes. For determination of optimum number of passes for given type of roller and optimum thickness of layer at a predetermined moisture content, a field trial for compaction is necessary as explained in Annexure -IV.

6.3.3 Compaction Procedures for Different Soils:

The embankments are constructed with locally available soils provided it fulfils the specified requirements. Procedure of compaction to be adopted will depend on the type of soil being used in construction. General guidelines to deal with compaction of various types of soils for attaining optimum dry density/relative density at minimum effort, have been briefly given as under:

6.3.3.1 Compaction of Cohesion Less Gravely and Sandy Soil:

- i) Sandy & gravely soils should be compacted with vibratory rollers. If fines are less in these types of soils, it can be compacted with minimum number of passes of vibratory rollers without strict control of moisture to achieve desired Relative Density. With higher percentage fines, sandy and gravely soils need to be brought to OMC level to get effective compaction. Uniformly graded sand and gravel are difficult to be compacted. Top layer of sand and gravel remains loose in vibrating compaction. Therefore, in final pass the roller should move smoothly without vibration. Dry densities attained in field trails normally should be around MDD/specified Relative Density as obtained from laboratory tests and should form the basis for specification and quality control.
- ii) Poorly graded sand and gravel with $C_u < 2.0$, should not be used in earthwork for the banks to safeguard against liquefaction under moving loads or especially due to earthquake tremor. Generally, fine sand is prone to liquefaction. Materials

Guidelines for Earthwork in Railway Projects

having gradation as per sketch 'D' should be specifically examined and designed to prevent possibility of any liquefaction.

6.3.3.2 Compaction of Silty - Clayey Soils:

Silty soil is a fine-grained soil. These can be plastic or non-plastic depending upon the clay content in it. Silts and fine sands with high water content have a tendency to undergo liquefaction under vibrating rolling due to the pore water pressure generated by mechanical work. Silty soils can be compacted satisfactorily near about OMC either with smooth rollers or vibratory rollers. Vibratory roller will give high degree of compaction and higher lift. Compaction of silty clays will have to be handled in a manner similar to clays.

6.3.3.3 Compaction of Clays:

- i) Water content plays very important role in compaction of clays. Main objective of compacting predominantly clays is to achieve uniform mass of soil with no voids between the lumps of clays. If moisture content is too high, roller tends to sink into the soil and if too low the chunks would not yield to rolling by rollers. Appropriate water content i.e. OMC of the soil is in the range of about plastic limit plus two percent. Sheepsfoot rollers are most effective in breaking the clods and filling large spaces.
- ii) Thickness of layer should not be more than depth of feet of roller plus 50 mm. Pad foot vibratory roller with drum module weight of 7tonne(total static weight of 11 tons) for a lift thickness of 30 cm is found quite effective for compaction of clays. For better results, initial rolling with static pad foot roller followed by 15 tons vibratory roller can be tried.

6.3.4 In case of such soils, the MDD and OMC, as determined in the Laboratory may not be very relevant and therefore achievable MDD and practicable moisture content at which such soils can be compacted effectively should be determined by conducting field trials.

6.3.5 Selection of Compacting Equipment:

The performance of roller is dependent mainly on type of soil used in construction. Guidelines on selection of compacting equipment are given in Annexure V. Vibratory rollers which can be used in static as well as dynamic mode with plain & pad drum, are now being manufactured by reputed Indian Companies also. Salient features of some of models are given in Annexure- VIII.

6.4 Placement of Back-Fills on Bridge Approaches and Similar Locations:

6.4.1 The back fills resting on natural ground may settle in spite of heavy compaction and may cause differential settlements, vis-a-vis, abutments, which rest on comparatively much stiffer base. To avoid such differential settlements, while on

Guidelines for Earthwork in Railway Projects

one hand it is essential to compact the back fill in the properly laid layers of soil, on the other hand, the back fill should be designed carefully to keep;

- i) Settlements within tolerable limits.
- ii) Coefficient of subgrade reaction should have gradual change from approach to the bridge.

6.4.2 Back-fills on bridge approaches shall be placed in accordance to para 605 of Indian Railways Bridge Manual 1998. Details given at Fig I.

6.4.3 Fill material being granular and sandy type soil, therefore need to be placed in 150mm or lesser thick layers and compacted with vibratory plate compactors.

6.4.4 While placing backfill material benching should be made in approach embankment to provided proper bonding.

6.5 Drainage Arrangement in Banks and Cuttings:

Drainage is the most important factor in the stability of bank/cutting in railway construction. Effective drainage of the rainwater in the monsoon season is very important to safe guard bank/cutting from failure. Railway formation is designed for fully saturated condition of soil. However, flow of water should not be allowed along the track as it not only contaminates ballast but also erodes formation. Stagnation of water for long time on formation is not desirable. Therefore, drainage system should be efficient enough to prevent stagnation and allow quick flow of water. Some guidelines on this aspect are given as follows:

6.5.1 Drainage of Embankment: In bank cross slope is provided from center towards end to drain out surface water. Therefore, normally there is no need of side drains in case of embankment. However, there are situations where height of bank is such that blanket layer goes below normal ground level. In such cases, side drains may require to be constructed along the track at suitable distance so that track alignment does not become channel for flow of ground surface water.

In case of double line construction, central drain between the tracks should be avoided to extent possible (even if it means resorting to additional earthwork to facilitate flow of water) as it is not only difficult to construct but also difficult to maintain for continuous vibrations caused by moving traffic, problem in proper curing of concrete etc. Only in very rare situations, when drainage of water is not possible without construction of drain, suitable arrangements for construction of drain with pre-cast concrete channel/ subsoil drains alongwith proper outfall should be made. If distance between adjacent tracks is large enough, suitable slope should be provided in ground to make rain water flow in natural manner. Wherever, there is level difference between two adjacent tracks, suitable non-load bearing dwarf wall may be constructed to retain earth.

6.5.2 Drainage in Cuttings:

6.5.2.1 Side Drains: In case of cuttings, properly designed side drains of required water carrying capacity are to be provided. If height of the cutting is less (say, up to

Guidelines for Earthwork in Railway Projects

4m), normally only side drains on both sides of the track are to be provided. In case of deep cuttings, catch water drains of adequate water carrying capacity are also required along with side drains. A typical sketch of side drain and catch water drain has been given in Sketch - E. It is to be noted that blanket material is to be placed like fill/embankment and top of side drains has to remain below the bottom of blanket material.

6.5.2.2 Catch Water Drains: Surface water flowing from top of hill slope towards the track in huge quantity needs to be controlled on safety consideration. It is also not possible to allow water from the hillside to flow into the side drains, which are not designed for carrying such huge quantity of water. Therefore, it is essential to intercept and divert the water coming from the hill slopes, accordingly, catch water drains are provided running almost parallel to the track. Depending on site condition, water from the catch water drains may require be diverting by sloping drains and carrying across the track by means of culvert. In some of the situations, depending on topography of top of cutting, there may be requirement of construction of net of small catch water drains which are subsequently connected to main catch water drain so that there is no possibility of water stagnation/ponding upto distance approximately three times depth of cutting from its edge. Catch water drains should be made pucca/lined with impervious flexible material locally available.

a) Considerations in Design of Catch Water Drains:

These should be properly designed, lined and maintained. If catch water drains are kuchha/ broken pucca drains, water percolates down to the track through cracks, dissolving the cementing material resulting into instability in the cuttings. Catch water drains should be located slightly away (as per site conditions) from the top edge of cutting and water flow should be led into the nearby culvert or natural low ground. Some additional salient features to be observed are as follows:

- i) Catch water drains shall have adequate slope to ensure development of self-cleansing velocity.
- ii) Catch water drains shall not have any weep hole.
- iii) The expansion joints, if provided, shall be sealed with bituminous concrete.
- iv) Regular inspection and maintenance work, specially before onset of monsoon, should be carried out to plug seepage of water.
- v) Catch water drains shall have well designed out fall with protection against tail end erosion.

Though capacity and section will depend on terrain characteristics, rainfall etc. but following parameters are important for design of catch water drains:

- Intensity and duration of rain fall.
- Catchment area- shape, size, rate of infiltration etc.
- Velocity of flow which should satisfy the Manning's formula
- Minimum gradient of drain should be in range of 1 in 400 to 1 in 700.

Guidelines for Earthwork in Railway Projects

- Normally catch water drains should trapezoidal cross section.
 - The catch water drain should not be given gradient more than about 1 in 50 (but in no case more than 1 in 33) to avoid high water velocity and possibility of washout of lining material
 - Rugosity coefficient should be about 0.03.
- b) Alignment plan, longitudinal section and soil survey records of catch water drain should be updated from time to time as per development in the area of influence.

6.6 Erosion Control of Slopes on Banks and Cuttings

Exposed sloping surface of bank/cutting experiences surfacial erosion caused due to the action of exogenous wind and water resulting into loss of soil, leading to development of cuts, rills/gullies adversely affecting the cess width, soil matrix, steepening of slopes etc which depends on type of soil, climatic conditions, topography of area, length of slope etc.

Erosion control measures are commonly classified in following categories:

- a) Conventional non-agronomical system,
- b) Bio-technical system,
- c) Engineering system, and
- d) Non- conventional hydro-seeding system.

Most common methods used are the Bio-technical and Engineering System. However, appropriate method needs to be decided depending on site conditions. These methods are explained in following paras

6.6.1 Conventional Non-agronomical System:

This system uses asphaltting, cement stabilisation, pitching etc. This method is best utilized against seepage, erosion by wave action etc.

6.6.2 Bio- Technical Solution:

In this system, vegetation is provided on exposed slopes. It is suited for soil with some clay fraction. Method consists of preparing slope area by grading it for sowing seeds or planting root strips of locally available creeping grass. Its root goes upto 50 to 75mm deep into the slopes serving as a soil anchor and offering added resistance to erosion. Some typical species of grass which develop good network of roots and considered suitable are listed below:

- Doob grass
- Chloris gyne
- Iponea gorneas (Bacharum Booti)
- Casuariva and goat foot creepers etc.
- Vetiver grass (vetiveria zizanioides)

6.6.2 Engineering System:

In this system, three methods, as mentioned below, are normally used.

Guidelines for Earthwork in Railway Projects

a) **Geo-jute :** In this system, geo-jute is used. The system is used in areas having high erosion problems. Geojute is eco-friendly material made of jute yarn with a coarse open mesh structure and is biodegradable. On degradation, it helps in growth of vegetation. It is of two types i.e. fast biodegradable and slow biodegradable. The methodology by which geojute on slopes of banks/cuttings should be provided is explained as follows:

- Top 50 to 75 mm soil should be made free of clods, rubbish, large stones etc.
- Top surface should be properly dressed.
- Seeding should be done by distributing evenly over the slope.
- Folded geojute should be buried at critical slippage of top soil.
- Geojute is then unrolled loosely and evenly.
- Up channel and shoulder are buried and stapled and then anchored as per the requirement of the supplier.
- Down channel ends and toes are folded and secured as per manufacturer's requirement.
- Wherever it is getting terminated, it should be buried as per specification.
- Longitudinal edge overlapping should be as per manufacturer's requirement and stapled at one meter interval.
- Rolled junctions are overlapped as per manufacturer's requirement.
- Up channel section over down channel additional row of staples is fixed at 1m interval down each strip.

Watering facility should be ensured during initial period of sowing if the work is undertaken during non-monsoon period. Post laying protection against stamping and grazing by cattle is required. In case of any damage, local spot repair should be carried out. Once vegetation is well established, no maintenance is required.

b) **Polymer Geogrids:** Under unfavourable soil and rainfall conditions where vegetative growth is difficult or is considered inadequate, a synthetic root reinforcement vegetation system using geogrids should be provided. Geogrids are flexible, non biodegradable, resistant to chemical effects, protected against ultraviolet degradation and are stable over a temperature of 60-100 °C. It provides root matrix reinforcement with dense vegetation growth which works as permanent measure against erosion. Simply extruded un-oriented and unstretched polymeric grids of low mass are considered adequate. In deep open cuttings with boulder studded strata , bi-axially oriented geogrids of low mass should be deployed with suitable anchors to retain the boulders in place till growth of vegetation is adequate. Following methodology should be adopted for laying at site.

Slope area should be dressed with filling of cavities and pot holes if any by light ramming. The net should be unrolled ensuring uniform surface contact. Geogrid ends at top and bottom of slopes should be suitably anchored in 50cm x 50cm size trenches. MS pins 6mm dia and 2m c/c should be used to hold the light weight net in position for an initial period of 2 to 3 months. Overlapping of grids (about 75mm) and jointing with 6mm dia, ultraviolet stabilised polymer braids is

Guidelines for Earthwork in Railway Projects

required to be carried out in longitudinal direction of laying. No overlaps are required in transverse direction of laying while jointing.

6.6.4 Hydro-seeding System:

This is non-conventional and innovative system of development of vegetation. This system can be tried on mountainous slopes and steep banks/cuttings. In this system, **Verdyol** mulch solution @ 100 to 150 gm/m² is sprinkled on the surface for germination of vegetation depending upon the local soil and the climatic conditions.

6.6.5 Protection of Slopes in Cutting:

- a) The causes and manifestations of surfacial erosion of slopes of banks and cuttings are almost similar. In case of cuttings, where the slopes are normally steeper than those of banks, special protection measures would be necessary. For cutting slopes steeper than 1:1 with soil conditions favorable for vegetative growth, turf sodding (size 20x20x7.5cm) should be transplanted from adjoining grassed area. To prevent slipping tendency of sodding patches, especially during rains, these should be anchored with wooden pegs.
- b) In case of cutting slopes, having exposure of medium to large size boulders embedded in erodable soil, special protection measures may be required till the growth of vegetation takes place. Low to medium strength (13 to 22 kN/m) and biaxially oriented geogrids should cover the exposed boulders studded slopes and suitably anchored. Prior to adequate vegetation growth, surfacial erosion developing dislodging tendency of small to medium sized boulders could be checked with the help of polymer nets.

6.7. Other Aspects of Construction of Earthwork

6.7.1 Execution of Earthwork- General aspects

- a) The spreading of material in layers of desired thickness over the entire width of embankment should be done by mechanical means and finished by a motor grader. The motor grader blade shall have hydraulic control suitable for initial adjustment and maintain the same so as to achieve the slope and grade.
- b) Thickness of layer is decided based on field compaction trials. However, as a good practice thickness of layer should be generally kept as 300 mm for fill material and 250 mm for blanket material in loose state before compaction.
- c) If natural moisture content (NMC) of the soil is less than the OMC, calculated amount of water based on the difference between OMC & NMC and quantity of earthwork being done at a time, should be added with sprinkler attached to water tanker and mixed with soil by motor grader or by other means for obtaining uniform moisture content. When soil is too wet, it is required to be dried by aeration to reduce moisture content near to OMC. Efforts should be made to keep

Guidelines for Earthwork in Railway Projects

moisture content level of the soil in the range of OMC \pm 2% at the time of compaction.

- d)** Fill shall be placed and compacted in layers of specified thickness. The rate of progress should be, as far as possible, uniform so that the work is completed to final level almost at the same time.
- e)** The rolling for compaction of fill material should commence from edges towards center with minimum overlap of 200 mm between each run of the roller. In final pass, roller should simply move over the surface without vibration so that top surface is properly finished.
- f)** Extra bank width of 500 mm on either side shall be rolled to ensure proper compaction at the edges. The extra soil would be cut and dressed to avoid any loose earth at the slopes. This should preferably be done with help of grade cutter.
- g)** At the end of the working day, fill material should not be left uncompacted. Care should be taken during rolling to provide suitable slope on top of the bank to facilitate quick shedding of water and avoid ponding on formation.
- h)** During construction of formation, there may be rainfall to the extent that rain cuts may develop on the surface of formation due to erosion of soil. Care should be taken that these rain cuts are not allowed to develop wide and deep otherwise these locations will remain weak spots. Provisions should be made in contract conditions to attend / repair such rain cuts , as a regular measure.
- i)** Top of the formation should be finished to cross slope of 1 in 30 from one end to other towards cess/drain in multiple lines and from center of formation to both sides in single line.
- j)** Once the top surface of the formation has been finished to proper slope and level, movement of material vehicle for transportation of ballast, sleepers etc. should be avoided, these movements will cause development of unevenness, ruts on the surface which will accumulate water and weaken the formation. The methodology of transportation of P. Way material needs to be planned.
- k)** In conversion/doubling/rehabilitation projects, suitable benching of existing slope shall be done before new earthwork is taken up to provide proper bonding between old and new earthworks. It should be ensured that there is no humus material left on the benched slope. Care needs to be taken to avoid entry of rainwater into the formation from this weak junction., otherwise this would result in development of weak formation, slope failure, maintenance problem due to uneven settlement etc.
- l)** At locations where the water table is high and the fill soil is fine-grained, it may be desirable to provide a granular layer of about 30 cm thickness at the base, above subsoil across the full width of formation.

Guidelines for Earthwork in Railway Projects

- m) At the places where embankment materials are not conducive to plant growth, top soil obtained from site clearance as well as top layer of borrow pit which is rich in organic content and suitable for plant growth, may be stored for covering slopes of embankment & cutting after construction, or other disturbed areas, where re-vegetation is required, as far as practicable.

6.7.2 Widening of Embankment:

Before taking up widening of existing of embankment for gauge conversion, it should be ensure that remedial measures for unstable formation have been taken.

- i) All vegetation shall be uprooted and taken away from the site of work. The loose materials removed from the slope should be dumped to form the bottom most layer on the ground in the width to be widened. If required, it shall be supplemented with local granular soil.
- ii) Starting from the toe, benching on the slope at every 30cm height shall be provided on the slope surface as in Sketch-E, so as to provide proper amalgamation between the old and new earthwork.
- iii) Earthwork shall be carried out in layers, each layer sloping out 1:30 and compacting it mechanically using vibratory rollers of around 0.9m width (which are available in the market), 6 to 8 passes of such rollers shall usually suffice to provide the compaction to the specified level.
- iv) The width of each layer of earthwork shall be in excess by 300mm of the designed profile to enable compaction near the edges. The excess width, thereafter, cut and dressed, so as to achieve the required bank profile.
- v) Earthwork shall be completed upto designed formation level keeping due allowance for the blanket if need be.

6.7.3 Raising of Existing Formation:

After widening of the bank to the level of the existing formation, raising shall be done as under:

- i) Raising less than 150mm shall be done with ballast, restricting overall thickness to 350mm.
- ii) Raising from 150mm to 1000mm, the existing ballast shall be taken out under suitable speed restriction and raising should be done in suitable steps with the material as per specification of blanket material, preferably that of upper blanket layer. After raising to the desired level, clean ballast shall be inserted.
- iii) Raising of more than 1000mm, under traffic, would not be cost effective and it may be desirable to lay a detour for passage of traffic temporarily. Final decision shall, however, be based on economic considerations.

6.7.4 Earthwork in New Detours:

To facilitate easing out of existing sharp curves, change of gradients and rebuilding of important bridges, new detours shall be necessary. Design and construction of such detours shall be carried out in accordance with this provisions in the Guidelines.

6.7.5 Use of Construction Equipments for Execution of Earthwork

Any manual methods of construction cannot achieve the desired quality of earthwork. It would be necessary to deploy modern equipments such as earthmover, motor graders, scraper, dumpers, mobile water sprinklers, vibratory rollers, sheepfoot rollers etc. as per need, on all projects, so that the quality of work is as per laid down standards. It would be desirable to maintain records of work done by various equipments at a particular site to assess the out put and quality control.

6.7.6 Construction of New Formation over Soft Compressible Sub-soil:

Various methods such as i) pre- loading and stage construction, ii) installation of vertical sand drains, and iii) installation of prefabricated vertical drains are available for strengthening of such weak soil by expediting consolidation. Selection of a particular method for safe construction of embankment will basically depend on rate of construction. Therefore, depending on site requirement and techno-economic considerations, a particular method for construction may be decided in consultation with RDSO.

6.7.7 Sandwich Construction of Banks with Cohesive Soils:

Sandwich type of construction may be adopted for construction of embankments with cohesive soils having very low permeability (less than 10^{-2} cm/sec.) and where height of bank is greater than 3m. In such situations, a layer of coarse sand ($C_u > 2$) of about 20 to 30 cm thick should be provided at bank height intervals of 2 to 3m. Sketch –G provides Guidelines for sandwich construction for different heights to improve factor of safety against slope failure, drainage and dissipation of pore water pressure. It is desirable to have a bottom layer of coarse sand in all cases where soils of low permeability is used even for depths upto 3m. However, before adopting such construction, it may be necessary to carry out a detailed technical study alongwith economics of sandwich construction, depending on site conditions and availability of material, if required, in consultation with RDSO.

6.7.8 Safety at Work Site:

Necessary precautions towards safety at work site, including doubling and gauge conversion, should be part of the contract document. Similarly, safety for staff working at site should be carefully ensured to avoid any untoward incidence. To the extent possible, the safety instructions are to be suitably incorporated in the

Guidelines for Earthwork in Railway Projects

contract document with clear understanding of responsibility of concerned staff and contractor about their responsibility.

6.7.9 Environmental Aspects:

Efforts should be made to ensure least disturbance to surrounding environment, to the extent possible. Wherever, there has been disturbance due to large scale construction, efforts need to be made to improve the surroundings and environment by way of massive group plantation, so as to restore the area. Rules and regulations of the government in vogue, in regard to the environment, need to be followed.

7.0 QUALITY ASSURANCE OF EARTHWORK

To achieve effective performance of permanent assets created in New line/Doubling/Gauge Conversion projects, adequate quality control/checks at all stages of construction viz. selection of construction materials, adoption of method, use of suitable machinery for construction and during execution of work is essential. Following quality control system needs to be adopted during execution of earthwork.

7.1 Setting up of GE Lab at Construction/Rehabilitation Site

A well-equipped GE Field Laboratory shall be set up at all construction projects connected with new lines, doubling and gauge conversion works as well as, where rehabilitation of failing formation is being undertaken. Number of such GE labs to be established on a particular project/work site would depend on the pace and length of work being executed at a particular site and the output of the lab so that all quality control checks can be performed effectively. The field lab should be manned adequately by trained official & staff capable of carrying out required investigation, soil testing and quality control at site.

a) Aspects to be looked after by field GE lab are as under:

- i) To ensure that the quality of supplied soil and blanket material conforms to the accepted limits of gradation, classification, plasticity, etc.
- ii) To evaluate method of compaction by conducting tests in connection with field trials.
- iii) To exercise moisture and density control as the earthwork proceeds in layers rolled with the suitable equipment.

b) Depending on the requirement, field lab shall be equipped with minimum equipments as listed in the Annexure-X to facilitate the following minimum tests:

- i) Gradation Analysis-Sieve and Hydrometer.
- ii) Atterberg's limits - liquid limit & plastic limit
- iii) Optimum Moisture Content (OMC), Maximum Dry Density (MDD) and Relative Density.
- iv) Placement moisture content & in-situ Density.

7.2 Quality Check of Earthwork

Quality of execution of formation earthwork shall be controlled through exercise of checks on the borrow material, blanket material, compaction process, drainage system and longitudinal & cross sectional profiles of the embankment. The summary of quality control of Earthwork has been given in Annexure – VII. The details of quality control procedure are as follows:

7.2.1 Quality Control on Construction Material:

This is required to ascertain the suitability of the material for construction of embankment and to decide the OMC and MDD, which become the quality control inputs for compaction control. Control tests are required to be done for borrow material as well as blanket material.

7.2.1.1 Borrow Material :

Fill material proposed to be used either from Railway land or from outside would have to be assessed for its suitability as well as to decide thickness of blanket layer, after conducting soil classification and other relevant tests as per site requirement. Further tests, if needed, should be performed as directed by engineer in-charge to fully assess the material. On the basis of the tests, areas for borrow material, especially from outside the Railway land, needs to be earmarked. Once the material has been found fit for use as fill material for embankment, further lab tests, to assess OMC, MDD/ Relative Density, need to be conducted. In case, slope stability analysis, as explained in para 4.4 is required, triaxial test will also be done to find effective shear parameters. It would be in the interest of the execution agency to have frequent tests conducted on his own to judge the suitability of the material to avoid any complication at a later stage. However, the final acceptance of the borrow material should be at the site where it is laid, as follows:

- (a) **Frequency of Testing at Site:** At least one test at every change of soil strata subject to minimum of one test for every 5000 cum to assess suitability of fill material and to lay down OMC and MDD/Relative Density.
- (b) **Acceptance Criteria:** Materials conforming to para 5.0 need only to be used for construction of embankment.

7.2.1.2 Blanket Material:

The source of blanket material, detailed in para 4.3.4.2, needs to be identified based on tests & studies conducted and conformity of the material to the Specification as laid down in para 4.3.4. It would be desirable to have a check on quality of material at source/manufacturing point so that major deviation in quality of the material being sent to site does not exist. It would be in the interest of the supplier to have such tests conducted on his own to avoid any complication at a later stage. The frequency of such test could be laid down by the engineer in-

Guidelines for Earthwork in Railway Projects

charge, if need be. However, the final acceptance of the blanket material should be at the site where it is laid, as follows:

- (a) **Frequency of Tests at Site:** Minimum one test per 500 cum or part thereof.
- (b) **Method of Test:** Blanket material should be tested as per IS: 2720 (Part 4) to plot particle size distribution curve, so as to assess its suitability. It would be necessary to carry out wet analysis to assess actual percentage of fines. To expedite testing work, dry sieve analysis may be carried out if variation between results of dry and wet analysis are not significant and adequate margin exists with respect to acceptance criteria. However, in such cases also, wet analysis has to be carried out at frequent interval to verify the extent of variation. In any situation, acceptance of blanket material would be based on wet analysis only. The samples for wet analysis should be prepared as per para 4.3 of IS: 2720 (Part 4).
- (c) **Acceptance Criteria :** The material should generally conform to specification as given at para 4.3.4.

7.2.2 Quality Control Checks on Finished Earthwork:

7.2.2.1 Compacted Earth: Degree of compaction of each layer of compacted soil should be ascertained by measurement of dry density/Relative Density of soil at locations selected in specified pattern. The method of sampling, frequency of tests, method of tests to be conducted and acceptance criteria to be adopted are as under

a) Method of Sampling :

- i) Various methods of selection of sample points for check of in-situ dry density are in vogue. These are shown in sketch-H. The sampling adopted has to be such that effectiveness of proper compaction having been done for the entire area under consideration can be judged.. For this, the Engineer in-charge should lay down the method adopted in detail depending on site conditions and accordingly records of checks done are properly maintained. However, in absence of such procedure laid down, following method should be adopted:

Suggested Method of Sampling: For each layer, a minimum of one sample at a predetermined interval (in compliance with the requirement stated in next para) along the centreline of the alignment, would be taken in a staggered pattern so as to attain a minimum frequency of tests as given in the para 7.2.2.1(b). For subsequent layer, the stagger should be such that the point of sampling does not fall vertically on the earlier sampling points of the layer immediately below. The process of sampling is explained in Sketch-H for guidance. Additional sampling points can be taken, as considered necessary.

- ii) In case of bank widening, sampling should be done at an interval of minimum 200metres on widened side(s) of embankment.

Guidelines for Earthwork in Railway Projects

b) Frequency of Tests: Density check would be done for every layer of compacted fill/blanket material as per following minimum frequency :

- i) At least one density check for every 200 sq.m for blanket layers and top one metre of sub-grade.
- ii) At least one density check for every 500 sq.m. for other than blanket and one metre of sub-grade.

In case of bridge approaches or special locations closer frequency may be adopted.

c) Method of In-situ Dry Density Measurements : Any of the following methods could be adopted as per the requirements at site.

Method of measurement	Procedure of test	Parameters to be measured	Remarks
i) Sand Replacement Method	As per IS-2720 (Part 28) 1974	a) Insitu Dry Density b) Moisture content	May be adopted for all type of soils
ii) Core Cutter Method	As per IS-2720 (Part 29) 1975	-do-	In some of the coarse-grained soils (with little fines) taking core cutter samples is difficult. In such cases, sand replacement method may be used for density measurement.
iii) Nuclear Moisture Density Gauge	As issued by RDSO	a) Bulk density b) Moisture content c) Dry density d) Degree of compaction	May be used in consultation with RDSO
iv) Compactor meters fitted on roller (On roller continuous compaction control)	As issued by RDSO	As issued by RDSO	May be used in consultation with RDSO.

d) Acceptance Criteria :

- i) Coarse grained soils which contains fines passing 75 micron IS Sieve, upto 5 percent should have the Density Index (Relative Density) a minimum of 70% as obtained in accordance with IS: 2720 (Part 14) – 1983.
- ii) For other soils, field dry density should not be less than maximum attainable dry density obtained in field compaction trial. However, in field compaction trial, the maximum attainable dry density should not be less than 98% of MDD values as obtained by Heavy Compaction Test (IS: 2720 (part 8) – 1983) in the laboratory.

Guidelines for Earthwork in Railway Projects

In case, there are difficulties in achieving 98% of the MDD values as obtained by Laboratory test, in the field trials, the same may be relaxed upto 95% of MDD with the specific approval of Chief Engineer/construction, recording reasons of such relaxation.

- iii) During widening of bank in case of gauge conversion and rehabilitation of unstable formation, compaction of earthwork should be minimum 95% of MDD as obtained by Laboratory test as per Heavy Compaction Test (IS: 2720 (part 8) – 1983) or 70% Relative Density for cohesionless soil (IS: 2720 (Part 14) – 1983).

7.2.2.2 Formation Level: Finished top of sub-grade level may have variation from design level by ± 25 mm and finished top of blanket layer may also be permitted to have variation from design level by plus 25 mm. The ballast should be placed only on level formation without ruts or low pockets.

7.2.2.3 Cross Slope: Cross slope should be within 1 in 28 to 1 in 30.

7.2.2.4 Side Slopes: Side slope should in no case be steeper than designed side slope. Provision of berm width should not be less than the designed width.

7.2.2.5 Formation Width: Formation width should not be less than the specified width.

7.3 Speed Of Section During Opening: Design and quality of construction should be such, so as to ensure opening of new lines, gauge conversions and doublings at full sectional speed and the same can be maintained through out the service life from geo-technical considerations.

8.0 MAINTENANCE OF RECORDS

At work site, details of works along with materials being used are to be properly recorded so that work of satisfactory quality can be achieved which can also be verified at later stage. Records are also required to be maintained to develop completion drawings and other details, which would become permanent records of the section and could be helpful in future to plan developmental activities and remedial measures if need be. Some of important records to be maintained are as follows:

8.1 Quality Control Records: At least, following records of quality control as per proformas given in Annexure – VI, needs to be maintained.

- i) Characteristics of borrow materials as per proforma No. 1 of Annexure – VI
- ii) Quality of blanket materials as per proforma No. 2 of Annexure – X.
- iii) Field compaction trial details as per proforma in Table 3 of Annexure – IV
- iv) Quality of compaction of earthwork including blanket material as per proforma No. 3 for core cutter method & 4 of Annexure – X for sand replacement method.
- v) Quality of material and its compaction for back fill behind bridge approaches etc as per proforma No. 1,2,3 & 4 of Annexure – X.

Guidelines for Earthwork in Railway Projects

- vi) Details of machineries engaged in execution of earth work including its output as per proforma decided by field engineers.

8.2 Permanent Records: It would be desirable to prepare completion drawing of embankments and cuttings indicating details of special construction features like toe-walls, breast wall, catch and side drains, cross section of embankment/ cutting, type of soil in subgrade and depth of blanketing material, geological features etc. These permanent records need to be handed over to open line at the time of handing over section of the section for maintenance.

9.0 ASSOCIATION OF GE CELLS OF RAILWAYS AND RDSO IN CONSTRUCTION AND REHABILITATION PROJECTS

9.1 New line/Doubling/Gauge Conversion works are to be executed by Railway, as per Guidelines issued by RDSO. Railways should ensure proper quality control over earthwork. RDSO may be consulted for help in establishing proper testing facilities, training of supervisors and for any problem of formation encountered in the work.

9.2 Requirement of thickness of blanket and slope stability analysis of bank/cutting should be worked out in advance and approval of competent authority (HOD in-charge of GE cell of Railways) is taken.

9.3 Any special design problems related with construction of formations may be referred to RDSO for guidance and advice.

9.4 All formation rehabilitation schemes need to be framed by railways themselves in consultation with respective GE cell on railways. It is the responsibility of executive authority to ensure that formation rehabilitation work is carried out in accordance with rehabilitation scheme and adequate control is exercised in execution. However, RDSO may be approached to provide consultancy on weak formation, if required.

9.5 Certification for quality of earthwork in formation in respect of New lines, Gauge Conversion and Doubling projects etc. will be done by Executive authority at SAG level (i.e. CE/Con of respective projects). CE/Con will submit details for certification of quality of earthwork to CRS as per RDSO check list titled as 'Check List for Certification of Earthwork, June 2004. (CS No.1 Dated 22.07.2004)

10.0

REFERENCES:

- 1 HMSO (1952) – “ Soil Mechanics for Road Engineers”
- 2 IRC Highway Research Board, New Delhi 1999 – State of Art: Compaction of Earthwork and Subgrades”.
- 3 Ministry of Railways (Railway Board) – 1982 – “Engineering Code”
- 4 RDSO – 1971 Civil Engineering Report no: C-112 – “Studies on compaction of Soil – Performance of CP –387 Triple Tamer (CPT) Make.
- 5 RDSO 1972 – Civil Engineering Report no: C – 127 – Report on a study of the Characteristics of compacted and uncompacted Expansive Soils”
- 6 RDSO (1977) – Civil Engineering Report no: 157 “ Compaction Characteristics of Black Cotton Soils.
- 7 Sherard, James: Woodward J. Raichard, Gizienki Stanley F, and Clevenger Willia (1963) “ Earth and Earth-Rock, Dams Engineering Problems of Design and Construction” John Wiley & Sons, inc, New York.
- 8 Terzaghi, K and Peck, R.B. (1967) – “Soil Mechanics in Engineering Practice” – John Wiley & Sons.

Guidelines for Earthwork in Railway Projects

- 9** United States Department of the Interior, Bureau of Reclamation (1968) – “Earth manual”
- 10** Specifications for Road and Bridge Works-2001, published by Indian Roads Congress, New Delhi.
- 11** Recommended practice for the construction of earth embankments for road works published by The Indian Roads Congress, 1995.
- 12** State-of-the-Art Report on Quality of Blanket material on Railway Formations, RDSO Report No. GE-37.
- 13** Esveld Coenraad - “Modern Railway Track”
- 14** Selig E.T. & John M.Waters – “Track Geo-technology and Substructure Management”
- 15** Civil Engg. Report no. CE- 267, - ‘Role of residual shear strength in railway formation and its determination’, Dec., 1991
- 16** Japan Railway Technical Service – “Measures for Stabilisation of Railway Earth Structures”.
- 17** A. Trenter, " Earthwork - A Guide",2001
- 18** A.Gomes Correia, 'Geotechnics for Roads, Rail Tracks and Earth Structures,2001, A.A.Blakema Publishers, Proceedings of European Technical Committee No. 11 of ISSMGE.
- 19** R. Kerry Rowe – “Geotechnical and Geo-environmental Engg.”.
- 20** Hilf J.W., ‘A rapid method for construction control for embankment of cohesive soil, ASTM special publication No. 232, 1957.

Guidelines for Earthwork in Railway Projects

SKETCH-A
(Para no. 2.0)

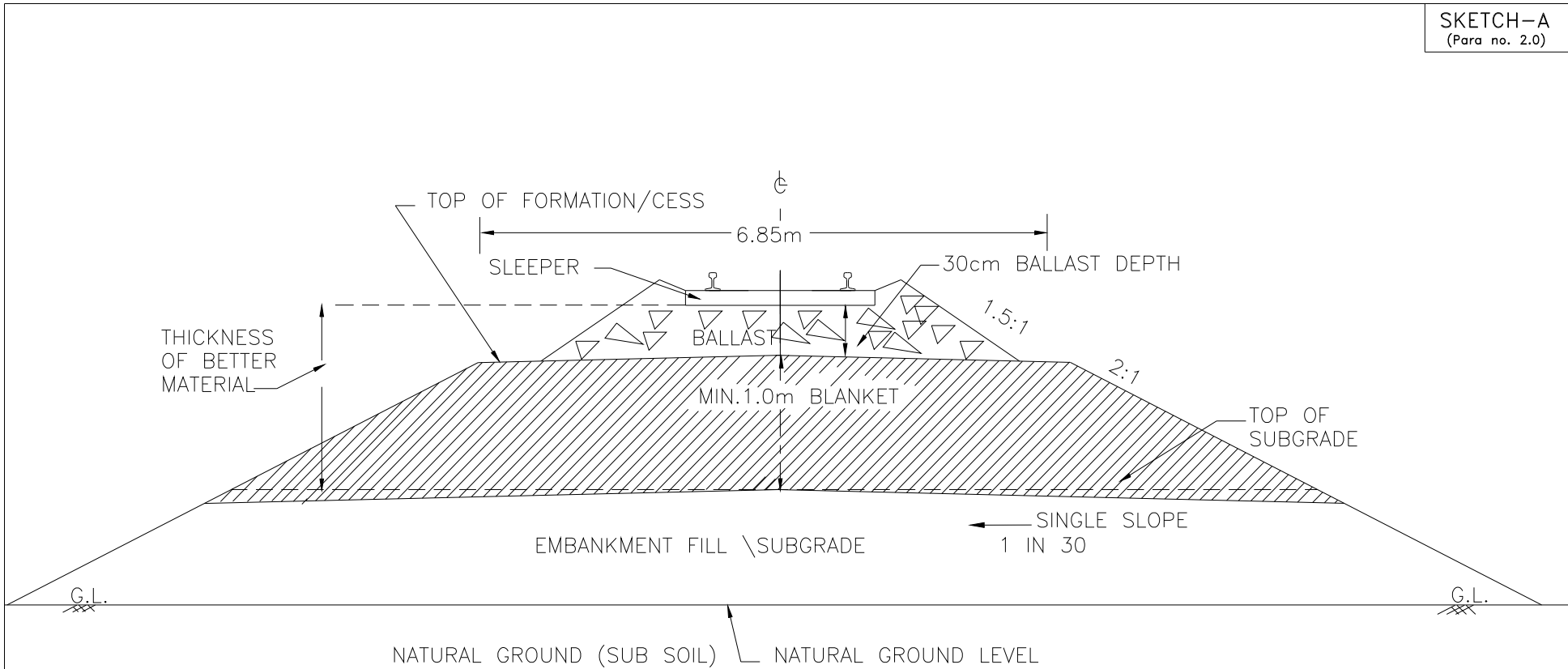

TRACK STRUCTURE – RAIL, SLEEPER, FASTENING

TRACK FOUNDATION – BALLAST, BLANKET & OTHER CONSTITUENTS

R. D. S. O.

GUIDELINES FOR EARTHWORK IN RLY. PROJECTS

BG TRACK SHOWING
THE NOMENCLATURE OF
VARIOUS ITEMS

NOT TO SCALE

DRG.NO.: GT/SK/GL/00254/Rev.0/2002

Guidelines for Earthwork in Railway Projects

SKETCH-B
(Para no. 4.3.4.1)

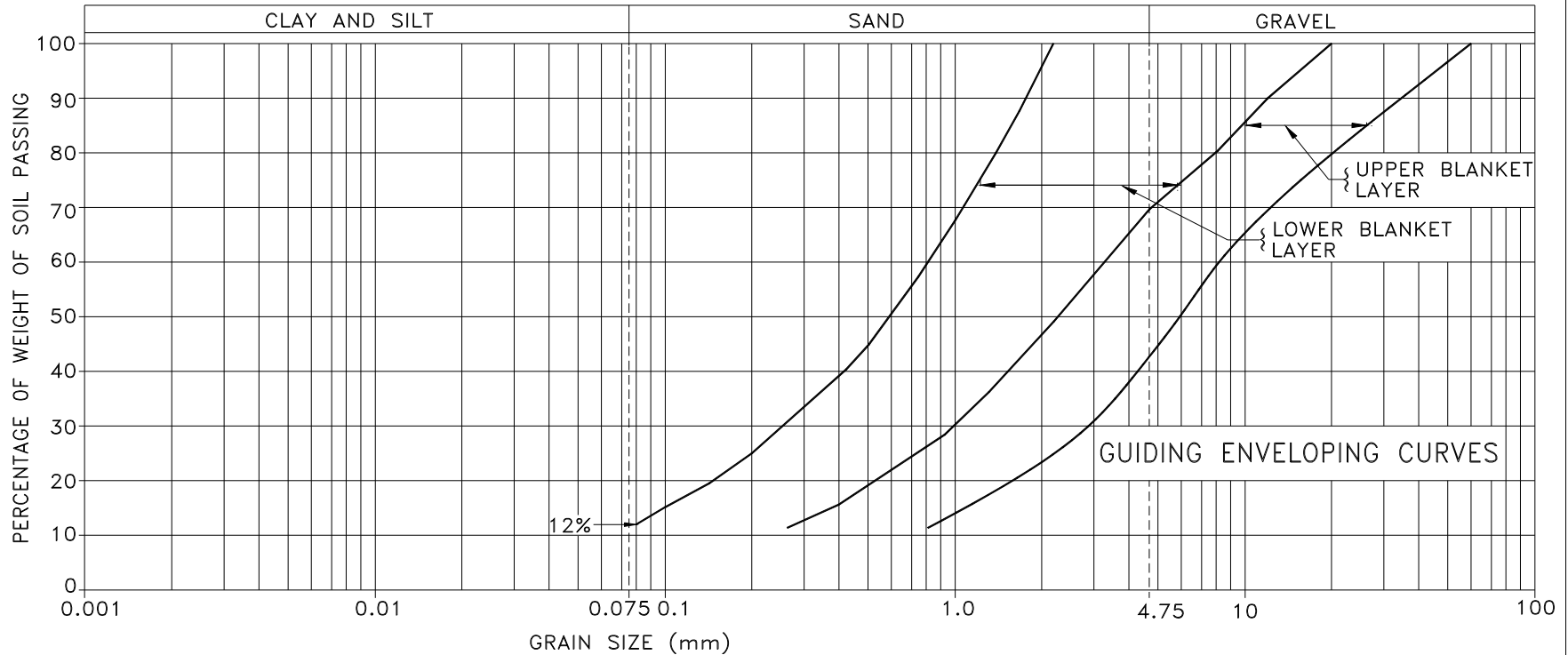

SPECIFICATIONS:

1. THE BLANKET MATERIAL SHOULD BE COARSE, GRANULAR AND WELL GRADED.
2. SKIP GRADED MATERIAL IS NOT PERMITTED.
3. PARTICLES FINER THAN 75 MICRONS CAN BE PERMITTED UPTO 5% IF FINES ARE PLASTIC AND THE LIMITS CAN BE INCREASED TO 12% IF THE FINES ARE NON PLASTIC.
4. UNIFORMITY COEFFICIENT (D_{60}/D_{10}), IN NO CASE SHOULD BE LESS THAN 4. PREFERABLY IT SHOULD BE MORE THAN 7.
5. THE COEFFICIENT OF CURVATURE ($D_{30}^2 / D_{60} \cdot D_{10}$), TO BE WITHIN 1 & 3.
6. THE PARTICLE SIZE GRADATION CURVE SHOULD LIE MORE OR LESS WITHIN GUIDING ENVELOPING CURVES.
7. LOWER BLANKET LAYER WILL BE PROVIDED FOR AXLE LOAD UPTO 22.5t AND UPPER BLANKET LAYER IS REQUIRED FOR HIGHER AXLE LOADS.

R. D. S. O.
GUIDELINES FOR EARTHWORK IN RLY. PROJECTS
SPECIFICATIONS FOR BLANKET MATERIAL
DRG.NO: GT/SD/0011/Rev.2/2001

Guidelines for Earthwork in Railway Projects

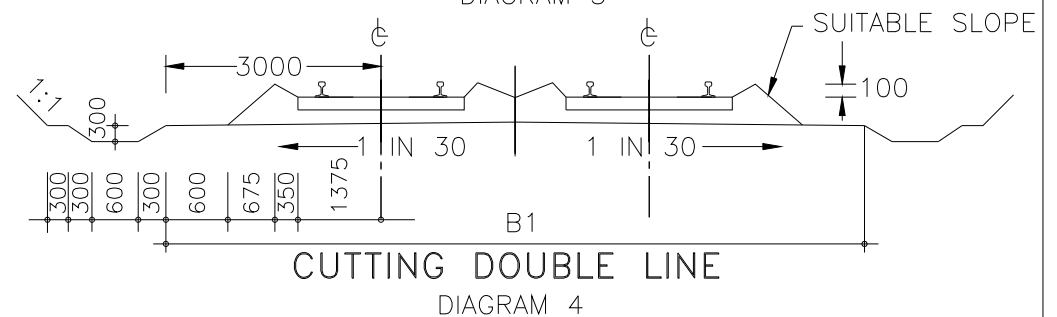
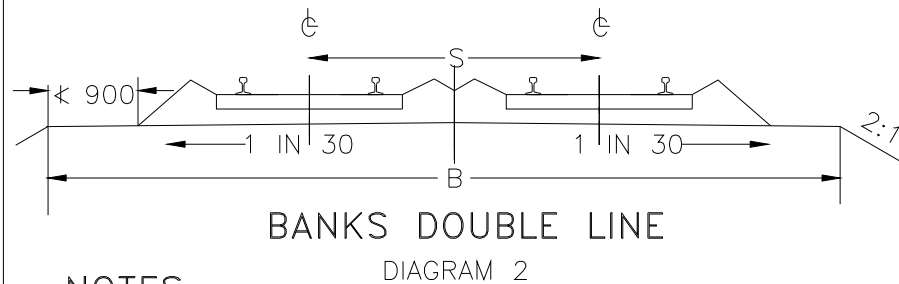
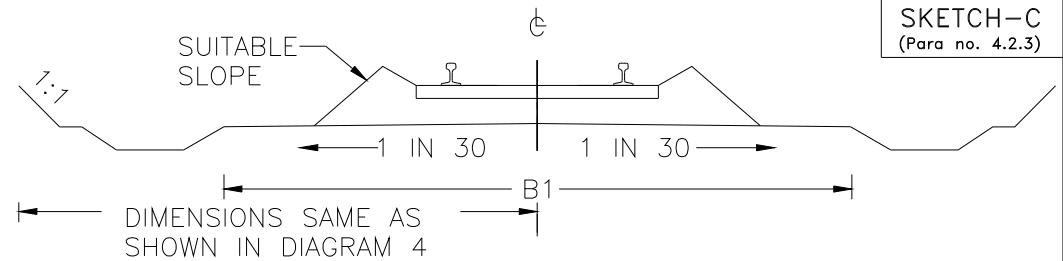
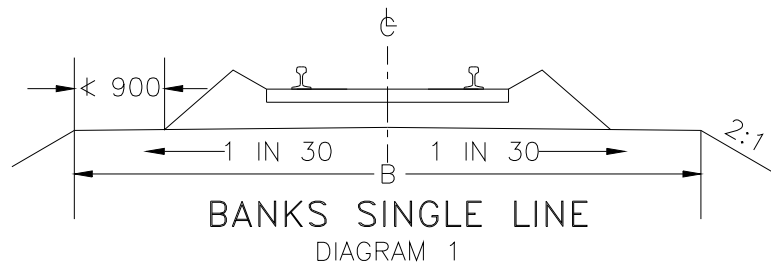

NOTES :

1. ALL DIMENSIONS SHOWN IN THE DIAGRAMS ARE IN mm.
2. ON BG AND MG DOUBLE LINES, THE MINIMUM FORMATION WIDTH IS BASED ON DISTANCE (S) BETWEEN TRACK CENTRES OF 5.30m AND 4.96m RESPECTIVELY.
3. IN FLAT TERRAINS THE HEIGHT OF BANK/DEPTH OF CUTTINGS SHOULD PREFERABLY BE NOT LESS THAN 1m FOR ENSURING GOOD DRAINAGE, FORMATION STABILITY AND TO AVOID TRESSPASSING.
4. THESE DIMENSIONS ARE BASED ON A BALLAST CUSHION OF 30cm.
5. THESE DIMENSIONS ARE ALSO APPLICABLE IN CASE OF ALL NEW LINES BECAUSE OF THE POSSIBILITY OF USE OF CONCRETE SLEEPER AT A LATER DATE.
6. ON CURVES THE FOLLOWING INCREASE IN FORMATION WIDTHS SHALL BE MADE:—
 - (1) FOR EXTRA BALLAST CUSHION ON OUTSIDE OF THE CURVE 0.15m ON SINGLE LINE AND 0.30m ON DOUBLE LINE (INCLUDING 0.15m INCREASE IN TRACK CENTRES).
 - (2) FOR EXTRA CLEARANCE REQUIRED ON DOUBLE LINE DUE TO EFFECT OF SUPER-ELEVATION ETC. AS STIPULATED IN APPENDIX TO THE SCHEDULE OF DIMENSIONS FOR BG./MG.
7. FORMATION WIDTH HAS BEEN CALCULATED ASSUMING A BALLAST SIDE SLOPE OF 1:1

SKETCH-C
(Para no. 4.2.3)

GAUGE	MINIMUM FORMATION WIDTHS			
	IN BANKS (B)		IN CUTTINGS (B1)	
	SINGLE LINE	DOUBLE LINE	SINGLE LINE	DOUBLE LINE
BG 1676	6.85m	12.16m	6.25m	11.55
MG 1000	5.85m	9.81m	5.25m	9.21m

R. D. S. O.

GUIDELINES FOR EARTHWORK IN RLY. PROJECTS

MINIMUM RECOMMENDED
FORMATION WIDTHS FOR
BANKS/CUTTINGS FOR
CONCRETE SLEEPER TRACK

NOT TO SCALE

DRG.NO: GT/SK/GL/0128/Rev.1/2002

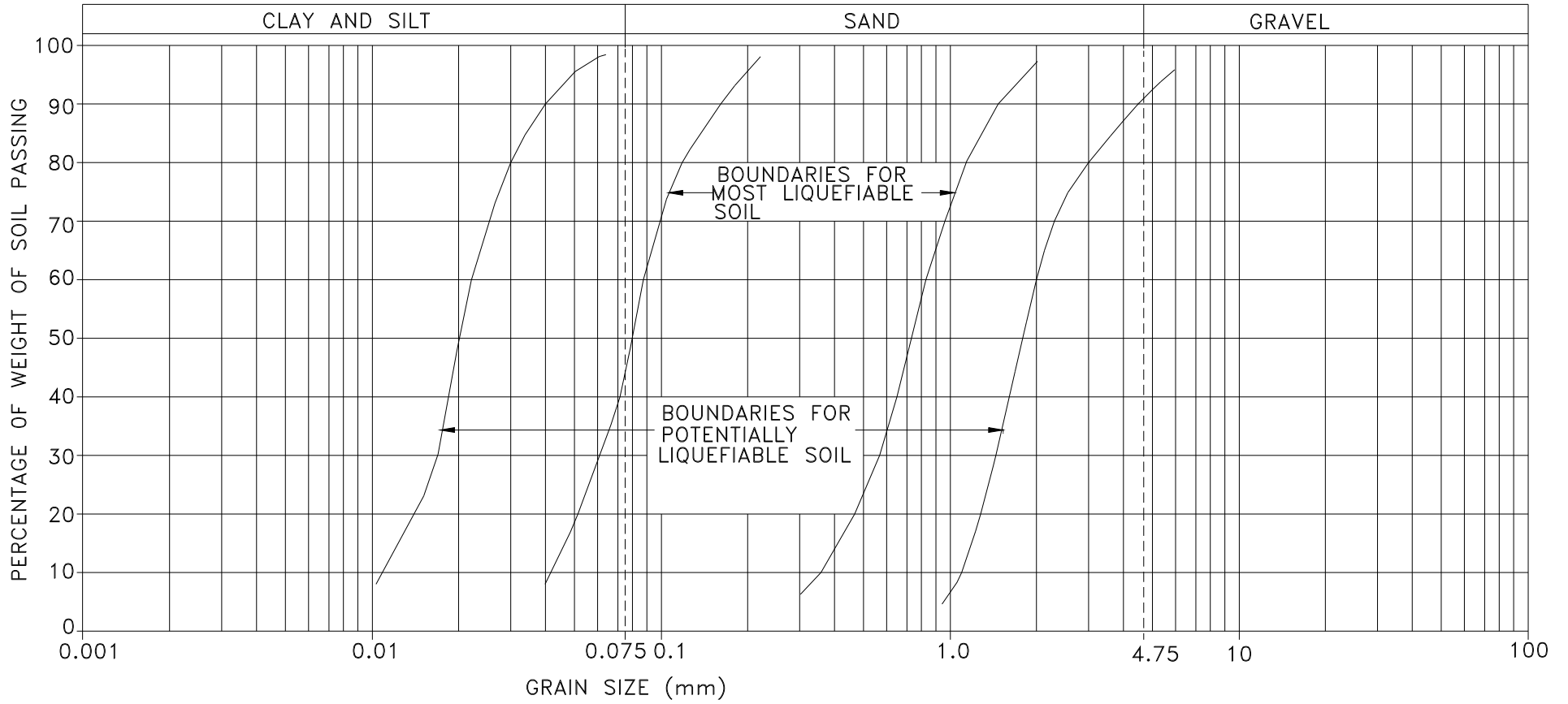

R. D. S. O.
 GUIDELINES FOR EARTHWORK IN RLY. PROJECTS
 LIMITING GRADATION
 CURVES SEPARATING
 LIQUEFIABLE AND NON-
 LIQUEFIABLE SOILS.
 DRG.NO: GT/SK/GL/0209/Rev.0/2001

Guidelines for Earthwork in Railway Projects

SKETCH-E
(Para no. 6.5.2.1)

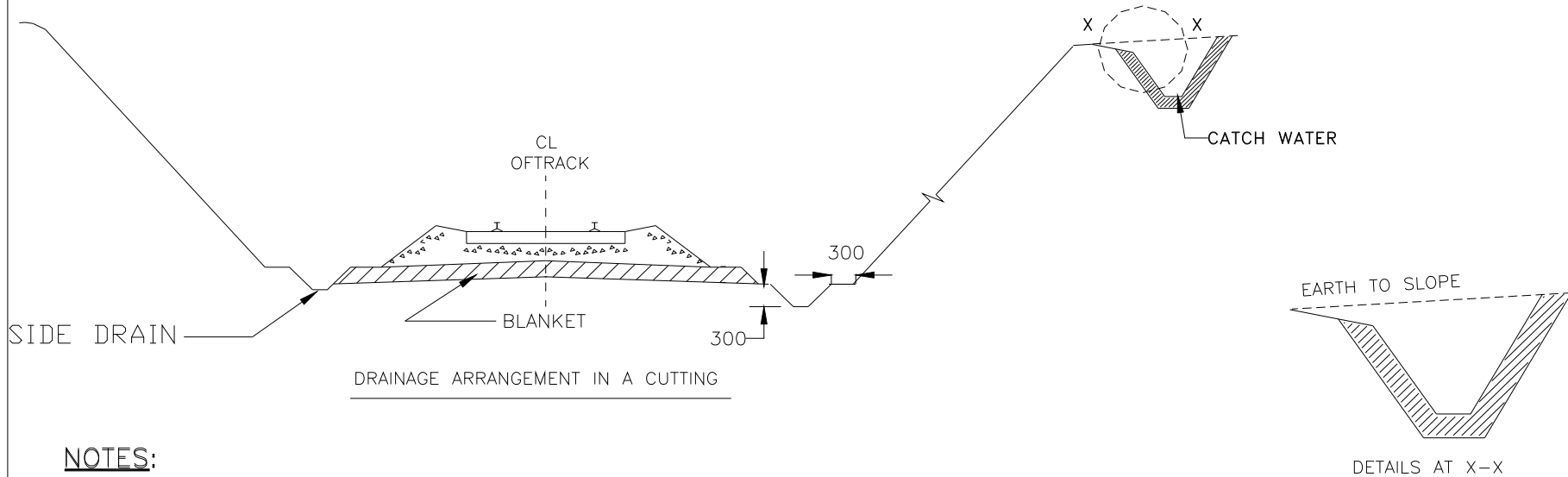

NOTES:

1. CATCH WATER DRAINS SHALL BE PROVIDED ON THE NATURAL GROUND IF FORMATION IN CUTTING IS LIKELY TO GET FLOODED FROM SURFACE WATER FLOWING ACROSS THE CUTTING OR WHEN DEPTH OF CUTTING IS MORE THAN 4m.
2. ALL CATCH WATER DRAINS SHALL BE PUCCA. THE EXPANSION JOINTS SHALL BE SEALED WITH BITUMENOUS CONCRETE.
3. THE CATCH WATER DRAINS SHALL HAVE SECTION ENOUGH TO CARRY 50% MORE THAN THE REQUIRED DISCHARGE TO CATER FOR ANY BLOCKADE OR SILTING.
4. CATCH WATER DRAIN SHALL HAVE ADEQUATE SLOPE TO ENSURE DEVELOPMENT OF SELF CLEANSING VELOCITY.
5. CATCH WATER DRAIN SHALL HAVE WELL DESIGNED OUTFALL WITH PROTECTION AGAINST TAIL-END EROSION.
6. CATCH WATER DRAIN SHALL NOT HAVE ANY WEEP HOLE.
7. SIZE OF SIDE DRAINS OF ADEQUATE CAPACITY SHOULD BE PROPERLY DESIGNED KEEPING IT'S BOTTOM LEVEL AT 300mm BELOW BOTTOM OF BLANKET LAYER.

NOT TO SCALE

R. D. S. O.
GUIDELINES FOR EARTHWORK IN RLY. PROJECTS
TYPICAL CROSS SECTION OF CUTTING SHOWING SIDE AND CATCH WATER DRAINS
DRG.NO. GT/SD/0005/Rev.1/2002

Guidelines for Earthwork in Railway Projects

SKETCH – F
(Para no. 6.7)

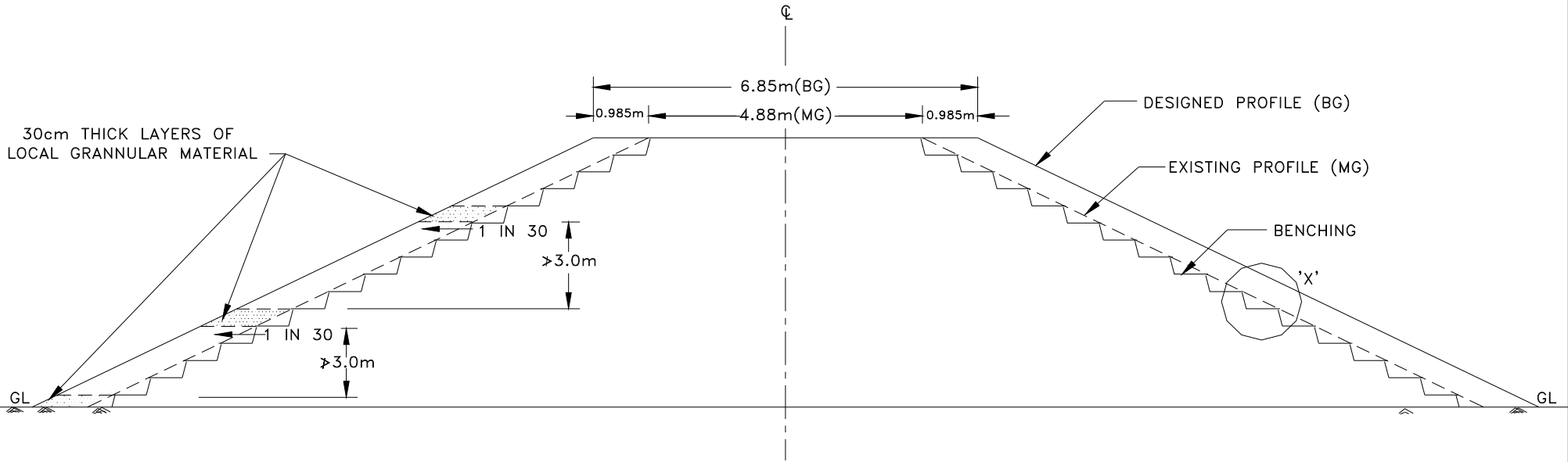

PROPOSED BANK SHOWN —————
EXISTING BANK SHOWN - - - - -

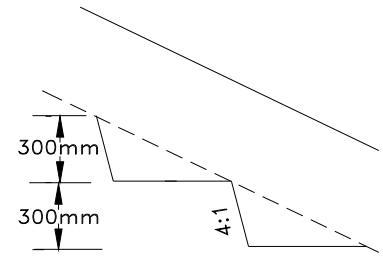

DETAILS AT 'X'

R. D. S. O.
GUIDELINES FOR EARTHWORK IN RLY. PROJECTS
SCHEME FOR BANK WIDENING SHOWING BENCHING & SANDWICH CONSTRUCTION
DRG.NO: GT/SK/GL/00259/Rev.0/2002

NOT TO SCALE

Guidelines for Earthwork in Railway Projects

SKETCH-G
(para no.6.7.7)

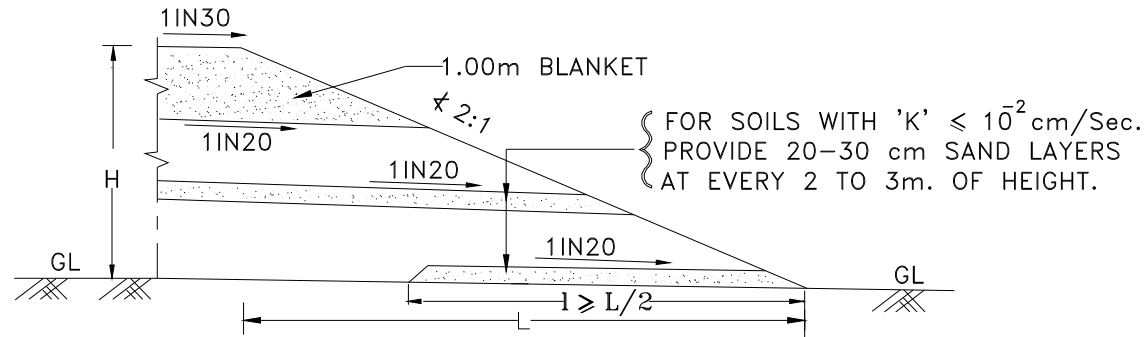

FIG. (a) $H \leq 6m$

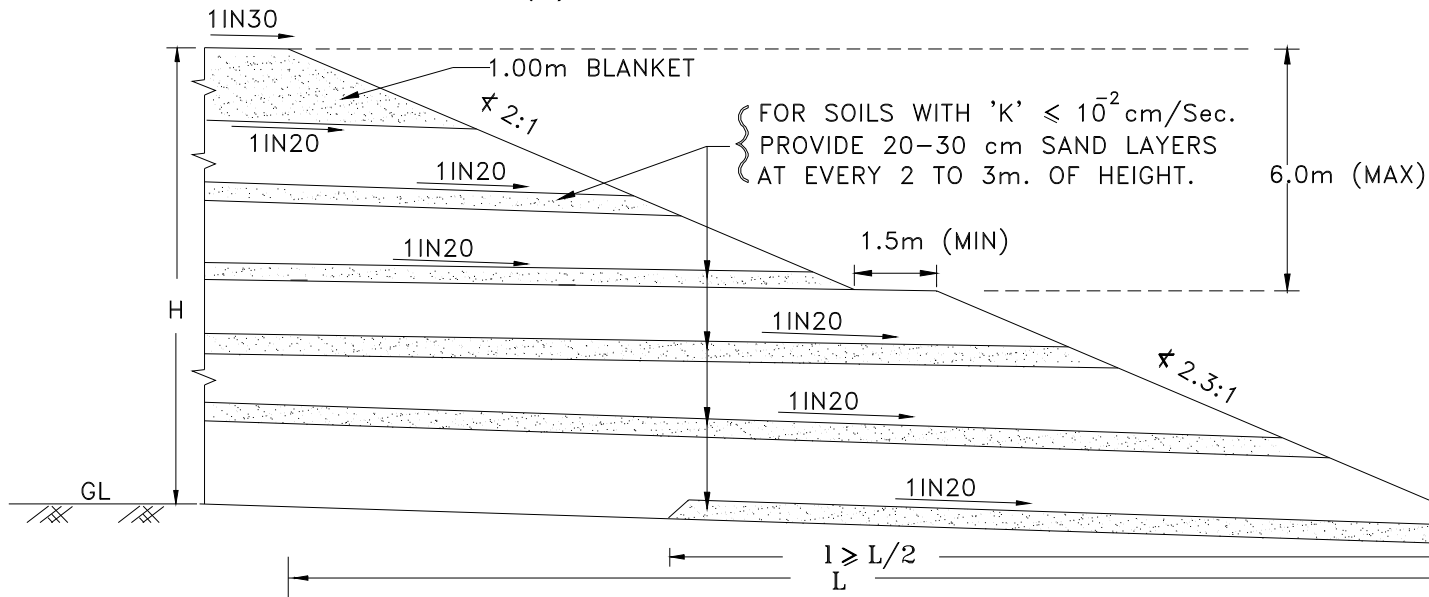

FIG. (b) $H = 6m \text{ TO } 12m$

NOTES:

1. FOR BANK OF HEIGHT MORE THAN 12m PROPER COMPUTATION FOR FAILURES AGAINST SLIPS, SETTLEMENT, ETC. SHOULD BE CARRIED OUT.
2. COEFFICIENT OF UNIFORMITY (C_u), OF SAND TO BE USED FOR SANDWICH CONSTRUCTION SHOULD BE GREATER THAN 2.

R.	D.	S.	O.
GUIDELINES FOR EARTHWORK IN RLY. PROJECTS			
TYPICAL EMBANKMENT PROFILE FOR SANDWICH CONSTRUCTION WITH COHESIVE SOILS			
DRG.NO: GE/SD/0019/Rev.0/2003			

SKETCH - H
(Para no. 7.2.2.1a)

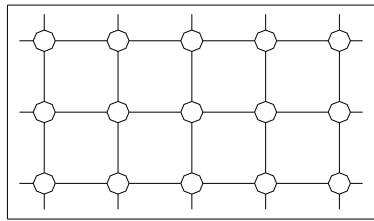

1. GRID PATTERN

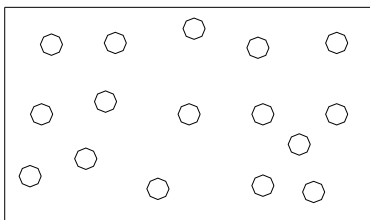

2. RANDOM SELECTION

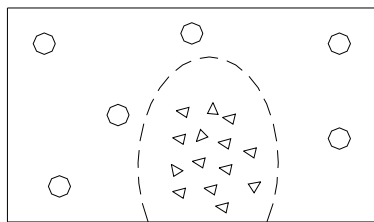

3. SUBJECTIVE SELECTION

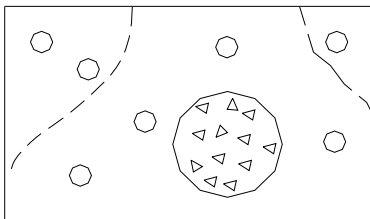

4. SUBJECTIVE SELECTION
USING AUXILIARY CRITERIA

DIFFERENT SAMPLING PATTERNS
FOR DENSITY CHECK

NOTE: x & y ARE SAMPLING INTERVALS
TO BE DETERMINED AS PER
SAMPLING AREA REQUIREMENT.
(REF. PARA 7.2.2.1b)

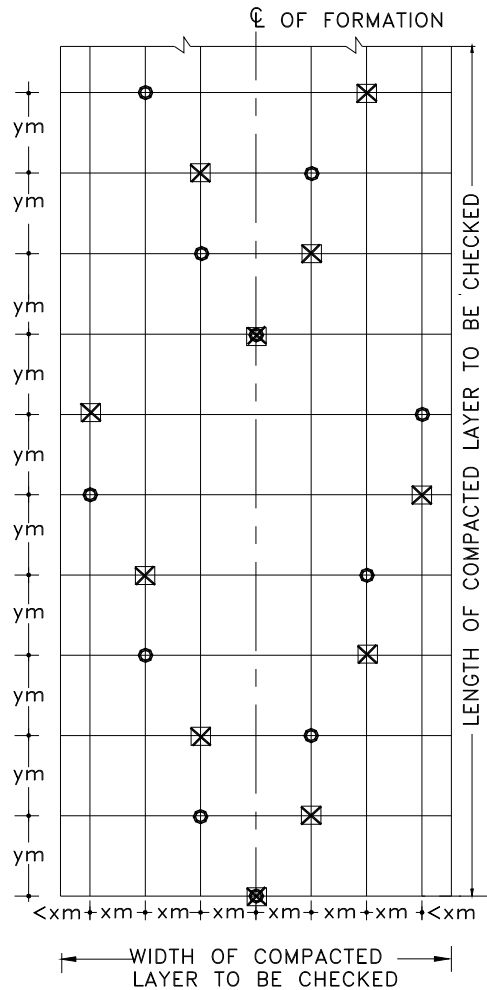

PLAN

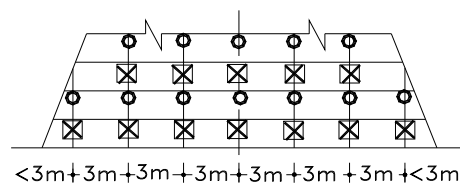

CROSS SECTION

LEGEND: **X** SAMPLING POINTS FOR A TYPICAL LAYER
O SAMPLING POINTS FOR NEXT LAYER

SUGGESTED SAMPLING PATTERN FOR
CHECKING OF DENSITY

R.	D.	S.	O.
GUIDELINES FOR EARTHWORK IN RLY. PROJECTS			
SAMPLING PATTERNS FOR CHECK OF COMPACTION			
DRG.NO.: GT/SK/GL/00253/Rev.0/2002)			

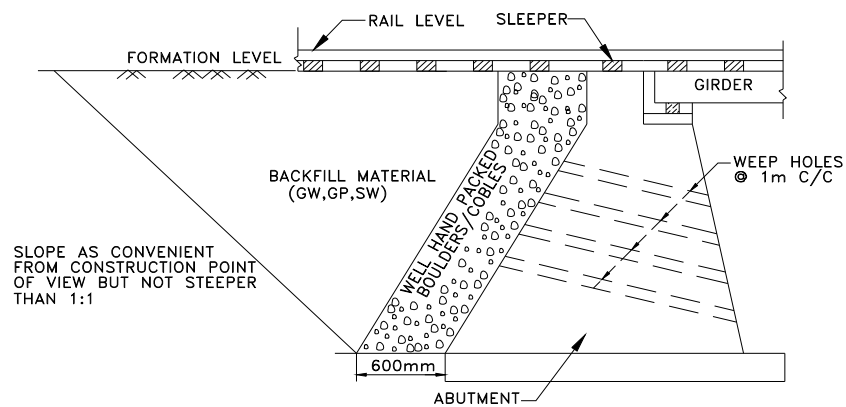

- NOTE:-
1. BEHIND ABUTMENTS, WING WALLS AND RETURN WALLS, BOULDER FILLING AND BACKFILL MATERIALS SHALL BE PROVIDED UPTO FULL HEIGHT.
 2. THE BOULDER FILLING SHALL CONSIST OF WELL HAND PACKED BOULDERS & COBBLES TO THICKNESS NOT LESS THAN 600mm WITH SMALLER SIZE TOWARDS THE BACK. BEHIND THE BOULDER FILLING, BACKFILL MATERIALS, SHALL CONSIST OF GRANULAR MATERIALS OF GW, GP, SW GROUPS AS PER IS: 1498-1970.

R. D. S. O.

GUIDELINES FOR EARTHWORK IN RLY. PROJECTS

DETAIL OF BACKFILL

BEHIND BRIDGE ABUTMENT

NOT TO SCALE

DRG.NO. GE/SD/0006/Rev.1/2002

BRIEF DETAILS OF SOIL CLASSIFICATION

(Ref: IS: 1498 - 1970)

Background and Basis of Classification:

The Geotechnical Engineers/Agencies had evolved many soil classification systems, over the world. The soil classification system developed by Casagrande was subsequently modified and named as 'Unified Classification' system. In 1959, Bureau of Indian Standards adopted, the Unified classification system as a standard, which was revised in 1970. According to BIS classification system, soils are primarily classified based on dominant particle sizes and its plasticity characteristics. Soil particles mainly consist of following four size fractions.

- Gravel : 80 – 4.75 mm
- Sand : 4.75mm – 0.075mm (75 micron)
- Silt : 75 – 2 micron
- Clay : less than 2 micron

Particle size distribution of a soil is determined by a combination of sieving and sedimentation analysis as per procedure detailed in IS: 2720 (Part 4) – 1985 and its plasticity characteristics are determined by Liquid Limit and Plastic Limit as per procedure detailed in IS:2720 (Part 5) –1985.

Symbols used in Soil Classification:

Symbols and other soil properties used for soil classification are given below. Brief procedure for Classification of soils has been explained in tabular form and Flow Chart. Plasticity Chart required for classification of fine grained soils has also been given.

Primary Letter

G : Gravel
S : Sand
M : Silt
C : Clay
O : Organic soil
P: Peat

Secondary Letter

W : well-graded
P : poorly graded
M : with non-plastic fines
C : with plastic fines
L : of low plasticity
I : of medium plasticity
H : of high plasticity

Other soil parameters required for soil classification:

- C_u : Coefficient of Uniformity = D_{60} / D_{10}
- C_c : Coefficient of Curvature = $(D_{30})^2 / (D_{60} * D_{10})$

- D_{60} , D_{30} & D_{10} are particle sizes, below which 60,30 and 10 percent soil particles by weight are finer than these sizes.
- Plasticity Index, $PI = \text{Liquid Limit (LL)} - \text{Plastic Limit (PL)}$
- Coarse-grained soils: Soils having fines (particles of size less than 75 micron) $< 50\%$
- Fine grained soils: Soils having fines more than 50%

Brief Procedure for soil classification:

Conduct Sieve analysis and Hydrometer analysis on soil sample and plot particle size gradation curve and determine C_u and C_c .

Conduct liquid limit and plastic limit test on soil samples.

Based on above soil parameters, classification should be done as per procedure explained in the following table/Flow Chart. The classification should be done in conjunction with the Plasticity Chart given below.

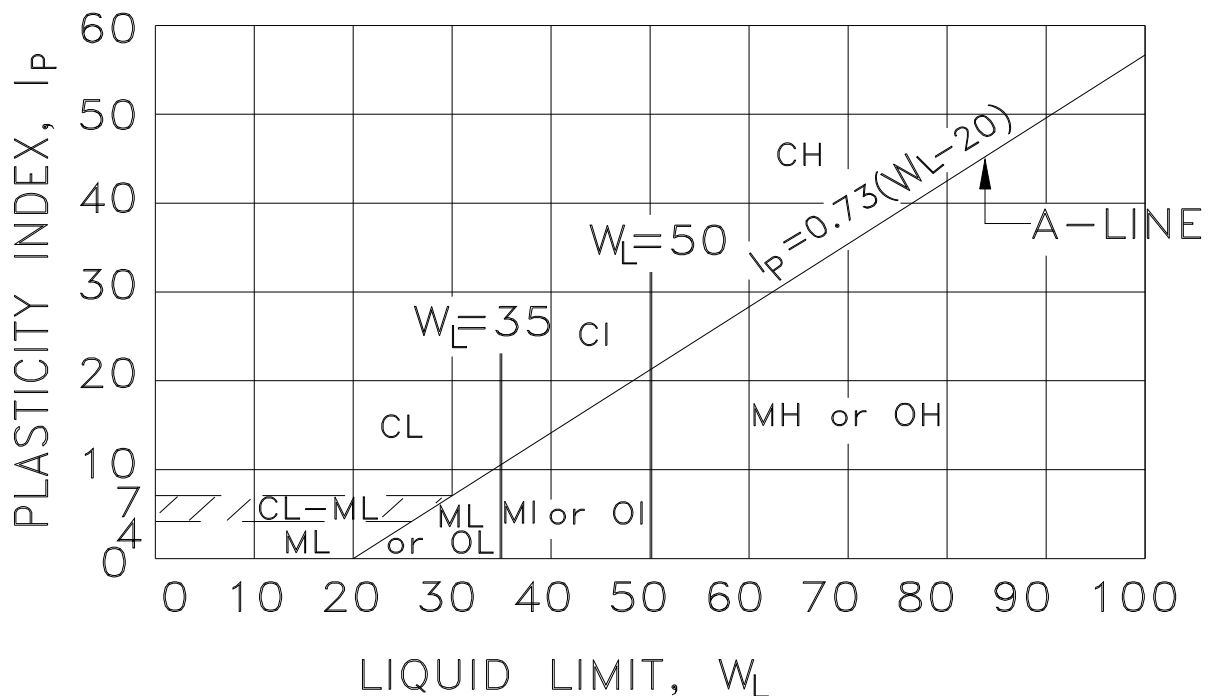

PLASTICITY CHART

TABLE EXPLAINING BIS SOIL CLASIFICATION SYSTEM

Description			Group Symbol	Laboratory criteria			Notes
				Fines (%)	Grading	Plasticity	
Coarse grained soils: Fine particles (size smaller than 75 micron) less than 50%	Gravels (particles larger than 4.75mm) more than 50% of coarse fraction	Well graded gravels, sandy gravels, with little or no fines	GW	0 - 5	Cu > 4 1 < Cc < 3		A dual symbol, if fines are 5 – 12 %.
		Poorly graded gravels, sandy gravels, with little or no fines	GP	0 - 5	Not satisfying GW requirements		
		Silty gravels, silty sandy gravels	GM	> 12		Below A- line or PI < 4	Dual symbols, if above A-line and 4 < PI < 7
		Clayey gravels, clayey sandy gravels	GC	> 12		Above A- line and PI > 7	
	Sands particles more than 50% of coarse fraction (size above 75 micron)	Well graded sands, sandy soils, with little or no fines	SW	0 - 5	Cu > 6 1 < Cc < 3		
		Poorly graded sands/,sandy soils, with little or no fines	SP	0 - 5	Not satisfying SW requirements		
		Silty sands	SM	> 12		Below A- line or PI < 4	
		Clayey sands	SC	> 12		Above A- line and PI > 7	
	Fine grained soils particles (size less than 75 micron) more than 50%	Silts and clays (Liquid Limit <35)	Inorganic silts , silty or clayey fine sands, with slight plasticity	ML	Plasticity Index less than 4		
			Inorganic clays, silty clays, sandy clays of low plasticity	CL	Plasticity Index more than 7		
Inorganic silt and clay of low plasticity			CL-ML	Plasticity Index between 4 and 7			
Silts and clays (Liquid limit 35-50)		Inorganic silts , clayey silt with medium plasticity	MI	Below A-line of Plasticity Chart			
		Inorganic clays, silty clays of medium plasticity	CI	Above A- line of Plasticity Chart			
Silts and clays (Liquid limit > 50)		Inorganic silts of high plasticity	MH	Below A-line of Plasticity Chart			
		Inorganic clays of high plasticity	CH	Above A- line of Plasticity Chart			

LABORATORY IDENTIFICATION PROCEDURE

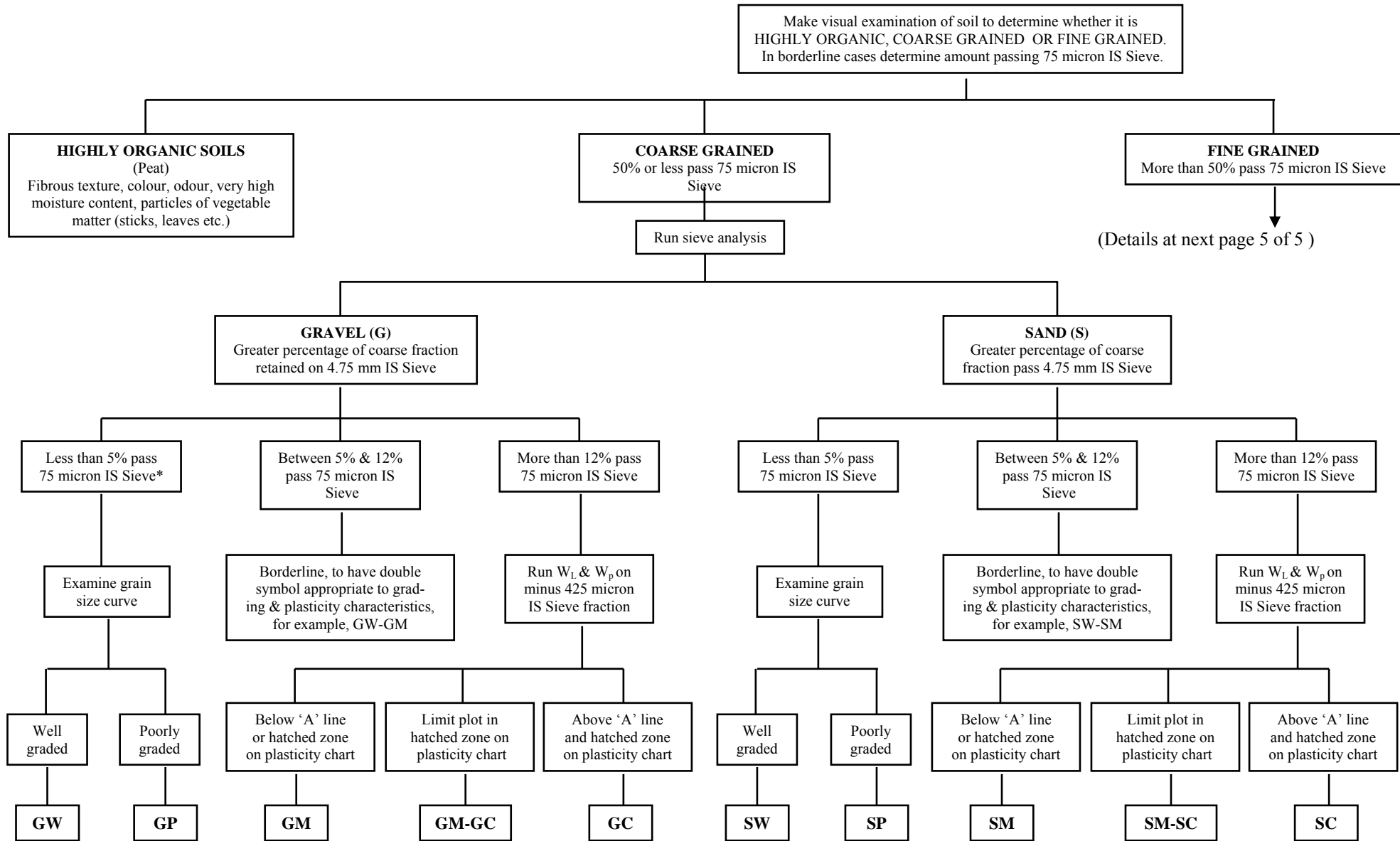

W_L = Liquid limit W_p = Plastic limit
*If fines interfere with free drainage properties use double symbol, such as GW-GM.

LABORATORY IDENTIFICATION PROCEDURE

(Continued from previous page)

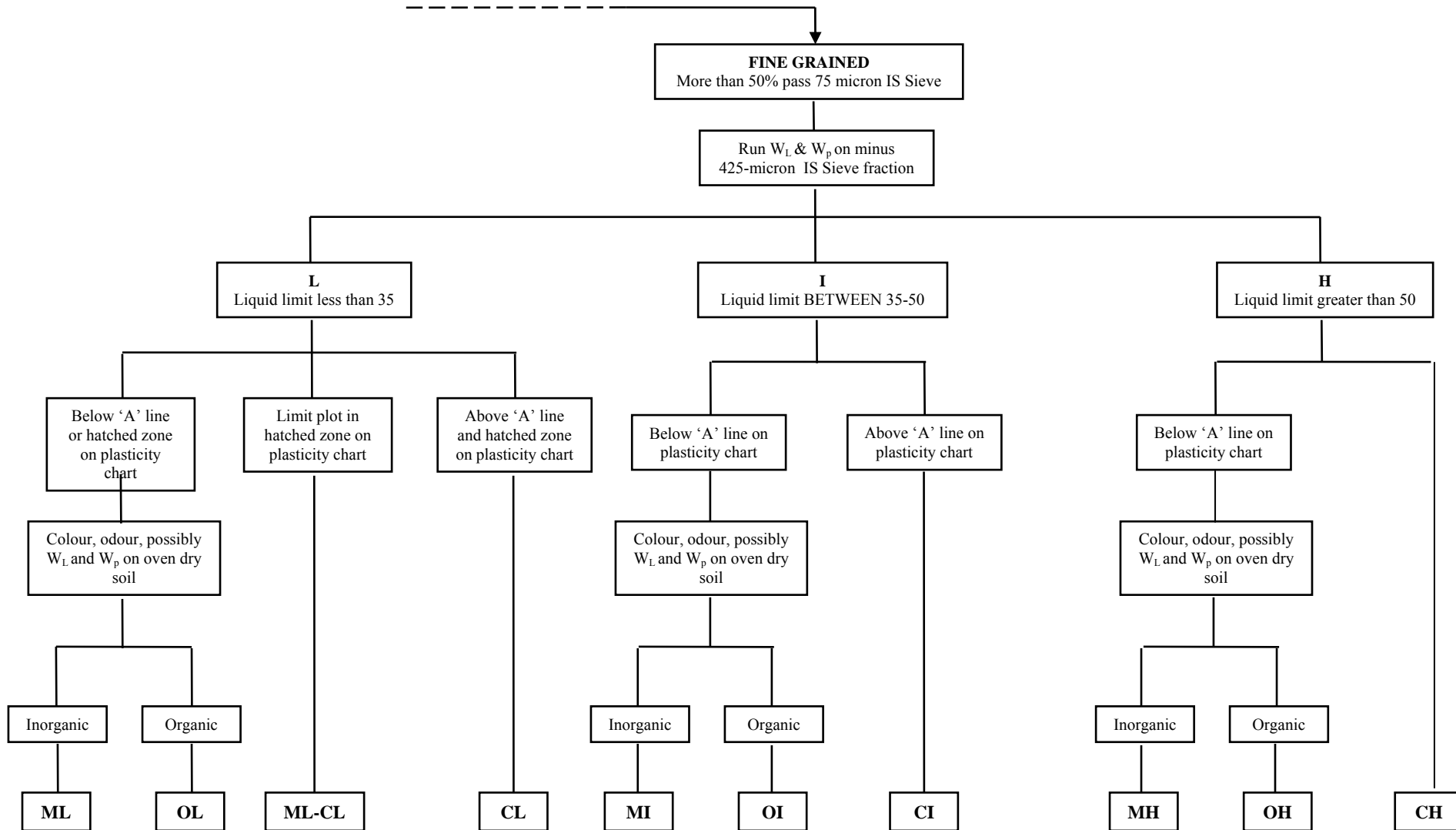

RELEVANT PARAS OF ENGINEERING CODE – 1982

CHAPTER IV: Engineering Surveys Reconnaissance – Preliminary and Final Location Surveys:

Para E 409: Field Work: The field work of a preliminary survey should include a compass traverse along one or more routes with such longitudinal and transverse levels as are sufficient to prepare a “Predicted Section” of the route or routes proposed. The fieldwork should also cover a soil survey by sampling at suitable intervals, in order to obtain a fair idea of the soil classification and characteristics on the proposed route/routes. Testing of disturbed soil samples is usually adequate but core drilling will have to be done rock.

Para E –425: In the case of a passage through hills, the geological characteristics of the country should be investigated by the Engineer, particularly in respect of the probable stability of the line, and if the importance of the work requires it, the Railway Administration should apply for the assistance of an Officer of the Geological Survey of India.

As the method of construction of earthwork will be dependent largely on the nature and classifications of and soils a systematic soil sampling at suitable intervals and upto sufficient depths depending upon the nature of terrain should also be done all along the proposed route. Wherever, borrow areas are not located along the alignment, soil samples should be collected from such places also. These samples shall then be tested for the standard properties, bore logs prepared and the data used for designing the profiles of the embankments and cuttings. Foundations of important structures as well as the method of undertaking the earthwork.

CHAPTER V: Engineering Surveys – Project, Report, Techno-economic survey Report & Feasibility report:

Project Engineering Estimation of Cost & Construction Schedule,

Para E 528 – Formation: Under this head details should be given regarding formation width on banks and in cuttings, side slopes of banks and cuttings, method of construction of earthwork, borrow areas, compaction of soil, use of special blanketing material, provision of sub bank, with supporting information on soil investigation and results of core drillings wherever necessary, provision for turfing or other protection for banks and cuttings and for repairing them and for topping banks with selected material, sections of tunnels, retaining walls, side drains and catch water drains.

Some times there is a discrepancy between the values of bench marks used by various departments of Government or by Railways in the neighbourhood from which the proposed line starts: and any discrepancy and any error in levels which are known to exist along the proposed line should be mentioned.

In the case of projects for additional lines and gauge conversions, if any, special arrangements are required for controlling the blasting for widening of existing cuttings, the method contemplated at the investigation stage may be indicated.

SLOPE STABILITY ANALYSIS METHOD

Ref:- RDSO's Circular No. GT/SPEC/007/Rev 0/1991 (earlier Circular No. 20 dt.4.9.91)

Based on experience gained, especially with the behavior of old banks and construction of new banks over soft clays, it has been decided that effective stress analysis shall be adopted for analysing end- of-construction and long – term - stability conditions, adopting realistic values of shear strength and pore water pressure parameters.

1. Conditions of analysis

Minimum factor of safety should be ensured for the following critical conditions:

- i) In embankments for a) end of construction, and b) Long term stability with vitiated spoil surface drainage such as when ballast is due for deep screening and during monsoon when drains get choked.
- ii) In cuttings, for long term stability with adverse conditions of drainage likely to develop in conjunction with modified sub-surface drainage patterns due to change of topography.

2. Factor of safety:

- 2.1 A factor of safety of 1.4 should normally be adopted against slope failure.
- 2.2 At the end of construction stage, when pore water pressure dissipates partially, a minimum factor of safety of 1.2 can be allowed to achieve economy but without sacrificing safety for long term – stability. Minimum factor of safety specified above can be further decreased only in specific cases of instrumented pilot embankments where the factor of safety is monitored during construction. However, in either case, a minimum factor of safety of 1.4 must be ensured for the long term-stability.
- 2.3 Moving train loads need not be considered in the slope stability analysis for embankments. Overstressing zones in soil mass due to live loads would affect the slope stability adversely because bearing capacity failure mechanism gets mixed up with slope failure mechanism. Hence, minimum FOS of 1.6 should be ensured for slope stability of smaller embankments of height upto 4m.

3. Computation procedure:

Computations shall be done using Bishop's simplified method for determining factor of safety against slips. For designing and checking of slopes of Railway banks and cuttings, stability tables from 3 to 20 as given in the end of this Annexure should be used. These tables were developed by Bishop's and Morgenstern 1960 with extension by MJO's Conner & Mitchel, 1976 and further by Chandler & Peiris,1989.

- 3.1.1 Formula to be used for the computation of factor of safety with Bishop's simplified method is:

$$F.O.S. = m - n \cdot r_u \text{ -----(1)}$$

Where: m & n are the stability co-efficient based on $C'/\gamma H$, ϕ' , depth factor and assumed slopes.(see table no 3 to 20)

C' = effective cohesion

ϕ' = effective angle of internal friction

γ = saturated unit weight of soil(s)

H = height of embankment

r_u = pore pressure ratio

D = depth factor

Note: i) Above parameters are explained in Fig. - 1

ii) Linear interpolation/extrapolation should be done for intermediate values of m & n

3.1.2 Pore pressure ratio, $r_u = U/\gamma \cdot h$ -----(2)

where:

U = pore water pressure

γ = bulk density of soil

h = depth of point in soil mass below sub-soil surface

3.1.3 Depth factor, $D = DH/H$ -----(3)

Where:

DH = total depth from the top of formation to hard stratum of sub-soil

H = height of embankment

a) Determination of Depth Factor:

Work out critical pore pressure ratio (r_{ue}), for depth factors, $D=1.0$ & 1.25 , as given below.

$$r_{ue} = m_{1.25} - m_{1.00} / n_{1.25} - n_{1.00} \text{ -----(4)}$$

Where: $m_{1.25}$, $m_{1.00}$, $n_{1.25}$ & $n_{1.00}$ are values of m & n at depth factors of 1.0 & 1.25

i) If $r_{ue} > r_u$ (eq. 2), depth factor, $D = 1.0$

If $r_{ue} = r_u$ (eq. 2), revised r_{ue} will be worked out as

$$r_{ue} = m_{1.50} - m_{1.25} / n_{1.50} - n_{1.25} \text{ -----(5)}$$

Where: $m_{1.50}$, $n_{1.50}$ etc. are values of m & n at depth factor of 1.50 etc.

ii) If this revised $r_{ue} > r_u$ (eq. 2), then $D = 1.25$

iii) If this revised $r_{ue} = r_u$ (eq. 2), then $D = 1.50$

Thus, depth factor will be taken 1.0 , 1.25 or 1.5 depending upon conditions of r_{ue} with respect to r_u (eq. 2) as worked out from i), ii) & iii)

Note: 1. Maximum value of depth factor is taken equal to 1.5 even if hard strata is not found up to $1.5H$ depth below formation level.

2. r_{ue} is worked out to decide depth factor only. For calculation of FOS, r_u as given in equation 2 will be used.

- 3.2 Determination of Shear Strength σ' and pore pressure parameters of sub-soils and bank soils for stability analysis shall be done as given in Fig. 1 & Table-1. However, for preliminary design or small projects, σ' and r_u values for different conditions can be taken from Fig. No. 2 & Table – 2.
4. Side slopes of embankments should not be steeper than 2:1. In case of clayey soils, for banks higher than 3m, flatter slopes would be necessary. Over compressible clays, provision of appropriately wide pre-load safe height is the most effective and economical solution.
5. Design parameters adopted should have the approval of the Director (GE), RDSO/ Chief Engineer In-charge of GE Cell (as the case may be). Design calculations for each embankment profile carried out should be recorded in the Design Register, showing soil parameters & factor of safety as adopted. In case of soft soils, most critical circle with its center, may also be indicated.

EXAMPLE OF CALCULATION FOR SLOPE STABILITY ANALYSIS

Design Data:

- a) Effective cohesion , $C' = 29.5 \text{ kg/cm}^2$
(measured in lab.)
- b) Effective angle of shear resistance , $\Phi' = 30^\circ$ (measured in lab.)
- c) Saturated density of soil, $\gamma_{\text{sat}} = 20 \text{ KN/m}^3$
- d) Pore pressure ratio, $r_u = 0.50$ (measured at site)
- e) Side Slope, $\cot\beta = 4:1$ (assumed safe side slope)
- f) Height of Bank, $H = 42.68\text{m}$

1. Value of $C' / \gamma H = 29.5/20 \times 42.68 = 0.035$
There is no direct table for this value therefore linear interpolation would be required between values of $C' / \gamma H$ of 0.025 & 0.05
2. For $C' / \gamma H = 0.025$, $\Phi' = 30^\circ$ and $\beta = 4:1$
- a) For $D = 1.00$; from table - 4
 $m = 2.873$ & $n = 2.622$
- b) For $D = 1.25$; from table – 5
 $m = 2.953$ & $n = 2.806$

3. To decide depth factor, r_{ue} will be computed as:

$$\begin{aligned} r_{ue} &= m_{1.25} - m_{1.00} / n_{1.25} - n_{1.00} \\ &= 2.953 - 2.873 / 2.806 - 2.622 \\ &= 0.43 < 0.50 (r_u) \end{aligned}$$

There is no table for $D = 1.50$, for $C' / \gamma H = 0.025$. Now, we will see for $C' / \gamma H = 0.05$

4. For $C' / \gamma H = 0.05$, $\Phi' = 30^\circ$ and $\beta = 4:1$

- a) For $D = 1.00$; from table - 6
 $m = 3.261$ & $n = 2.693$
 b) For $D = 1.25$; from table - 7
 $m = 3.221$ & $n = 2.819$
 c) Calculate r_{ue} to decide depth factor.

$$\begin{aligned} r_{ue} &= m_{1.25} - m_{1.00} / n_{1.25} - n_{1.00} \\ &= 3.221 - 3.261 / 2.819 - 2.693 \\ &= -0.32 < 0.50 (r_u) \end{aligned}$$

Therefore, workout r_{ue} for $D = 1.25$ & 1.50

- d) For $D = 1.50$; from table - 8
 $m = 3.443$ & $n = 3.120$
 e) Calculate r_{ue} again.

$$\begin{aligned} r_{ue} &= m_{1.5} - m_{1.25} / n_{1.5} - n_{1.25} \\ &= 3.443 - 3.221 / 3.120 - 2.819 \\ &= 0.73 > 0.50 (r_u) \end{aligned}$$

Hence $D = 1.25$ will be considered as more critical.

5. Therefore, FOS will be calculated for the value of $C' / \gamma H = 0.035$ at $D = 1.25$ as follows:

i) From para 2(b), FOS (for $C' / \gamma H = 0.025$) = $2.953 - 2.806 \times 0.5 = 1.55$

ii) From para 4(b), FOS (for $C' / \gamma H = 0.05$) = $3.221 - 2.819 \times 0.5 = 1.811$

- iii) Linear interpolation for $C' / \gamma H = 0.035$

$$\begin{aligned} \text{FOS} &= (1.811 - 1.55 / 0.05 - 0.025) \times 0.035 - 0.025 + 1.55 \\ &= 1.65 > 1.4 \end{aligned}$$

Hence, side slope of 4:1 is safe.

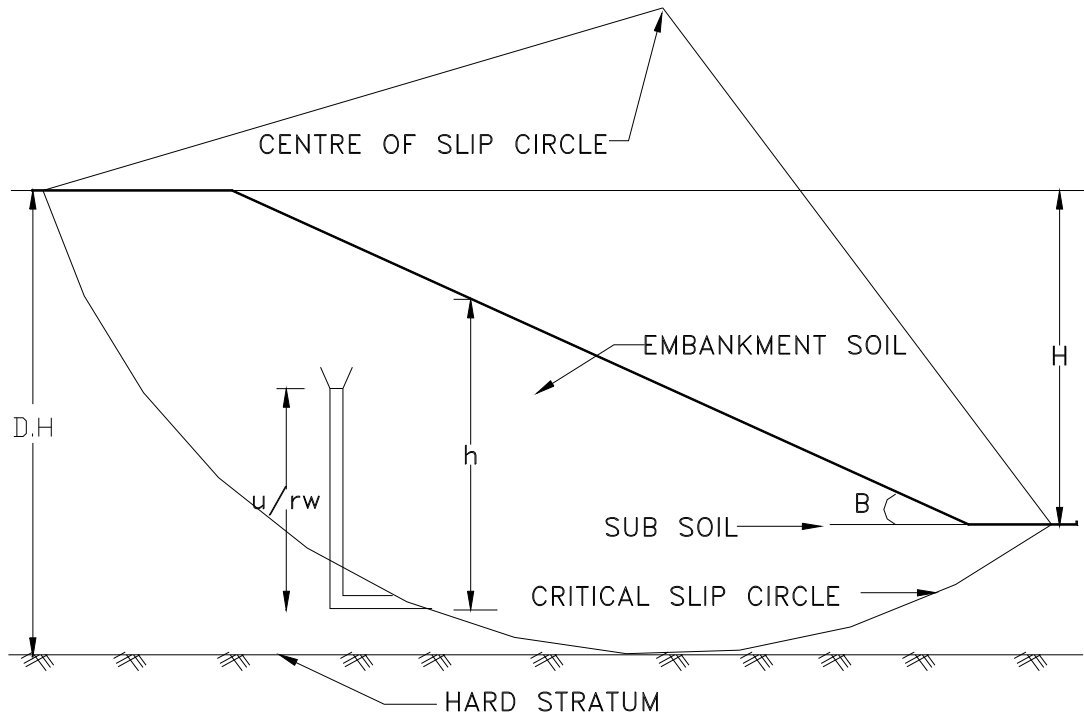
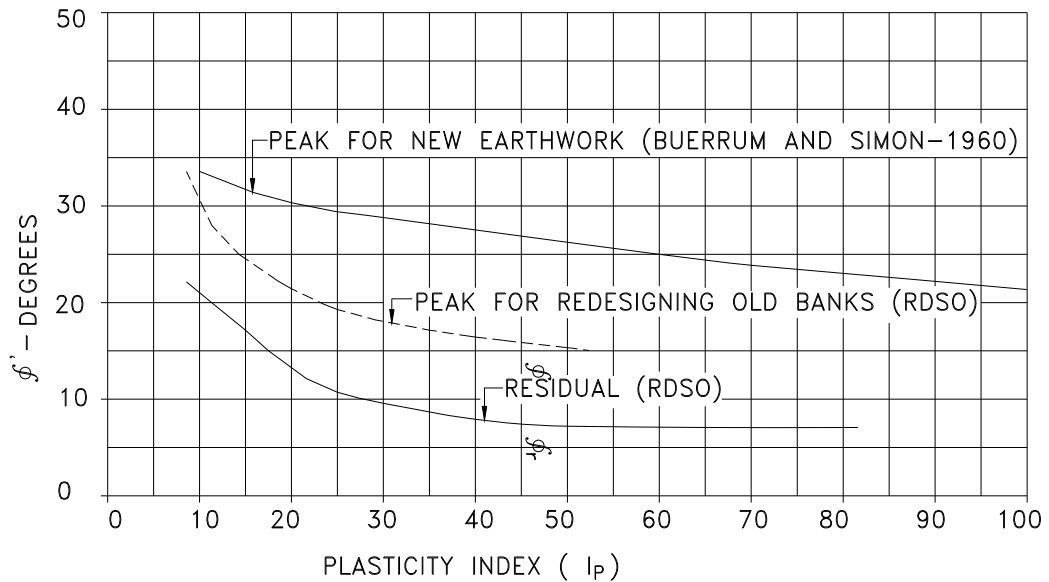

Fig. 1



DETERMINATION OF ϕ & c FOR RAILWAY BANK

Fig. 2

TABLE –3
STABILITY COEFFICIENTS m and n FOR $C'/\gamma H = 0$
STABILITY COEFFICIENTS FOR EARTH SLOPES

ϕ'	SLOPE 2:1		SLOPE 3:1		SLOPE 4:1		SLOPE 5:1	
	m	n	m	n	m	n	m	n
10.0	0.353	0.441	0.529	0.588	0.705	0.749	0.882	0.917
12.5	0.443	0.554	0.665	0.739	0.887	0.943	1.109	1.153
15.0	0.516	0.670	0.804	0.893	1.72	1.139	1.340	1.393
17.5	0.631	0.789	0.946	1.051	1.261	1.340	1.577	1.639
20.0	0.632	0.728	0.910	1.092	1.213	1.456	1.820	1.892
22.5	0.828	1.035	1.243	1.381	1.657	1.761	2.071	2.153
25.0	0.933	1.166	1.399	1.554	1.864	1.982	2.332	2.424
27.5	1.041	1.301	1.562	1.736	2.082	2.213	2.603	2.706
30.0	1.155	1.444	1.732	1.924	2.309	2.454	2.887	3.001
32.5	1.274	1.593	1.911	2.123	2.548	2.708	3.185	3.311
35.0	1.400	1.750	2.101	2.334	2.801	2.877	3.501	3.639
37.5	1.535	1.919	2.302	2.558	3.069	3.261	3.837	3.989
40.0	1.678	2.098	2.517	2.797	3.356	3.566	4.196	4.362

TABLE –4
STABILITY COEFFICIENTS m and n FOR $C'/\gamma H = 0.025$ & $D=1.00$
STABILITY COEFFICIENTS FOR EARTH SLOPES

ϕ'	SLOPE 2:1		SLOPE 3:1		SLOPE 4:1		SLOPE 5:1	
	m	n	m	n	m	n	m	n
10.0	0.678	0.534	0.906	0.683	1.130	0.846	1.365	1.031
12.5	0.790	0.655	1.066	0.849	1.337	1.061	1.620	1.282
15.0	0.901	0.776	1.224	1.014	1.544	1.273	1.868	1.534
17.5	1.012	0.898	1.380	1.179	1.751	1.485	2.121	1.789
20.0	1.124	1.022	1.542	1.347	1.962	1.698	2.380	2.050
22.5	1.239	1.150	1.705	1.518	2.177	1.916	2.646	2.317
25.0	1.356	1.282	1.875	1.696	2.400	2.141	2.921	2.596
27.5	1.478	1.421	2.050	1.882	2.631	2.375	3.207	2.886
30.0	1.606	1.567	2.235	2.078	2.873	2.622	3.508	3.191
32.5	1.739	1.721	2.431	2.285	3.127	2.883	3.823	3.511
35.0	1.880	1.885	2.635	2.505	3.396	3.160	4.156	3.849
37.5	2.030	2.060	2.855	2.741	3.681	3.458	4.510	4.209
40.0	2.190	2.247	3.090	2.993	3.984	3.778	4.885	4.592

TABLE -5
 STABILITY COEFFICIENTS m and n FOR $C'/\gamma H = 0.025$ & $D=1.25$
STABILITY COEFFICIENTS FOR EARTH SLOPES

ϕ'	SLOPE 2:1		SLOPE 3:1		SLOPE 4:1		SLOPE 5:1	
	m	n	m	n	m	n	m	n
10.0	0.737	0.614	0.901	0.728	1.283	0.887	1.288	1.014
12.5	0.878	0.759	1.076	0.908	1.299	1.089	1.543	1.278
15.0	1.019	0.907	1.253	1.093	1.515	1.312	1.803	1.545
17.5	1.162	1.059	1.433	1.282	1.736	1.541	2.065	1.814
20.0	1.309	1.216	1.618	1.478	1.926	1.776	2.334	2.060
22.5	1.461	1.379	1.808	1.680	2.194	2.017	2.610	2.373
25.0	1.619	1.547	2.007	1.891	2.437	2.269	2.897	2.660
27.5	1.783	1.728	2.213	2.111	2.609	2.531	3.193	2.976
30.0	1.957	1.915	2.431	2.342	2.953	2.808	3.511	3.299
32.5	2.139	2.112	2.659	2.585	3.231	3.095	3.841	3.638
35.0	2.331	2.321	2.901	2.841	3.624	3.400	4.191	3.998
37.5	2.536	2.541	3.158	3.112	3.835	3.723	4.563	4.379
40.0	2.753	2.775	3.431	3.399	4.164	4.064	4.958	4.784

TABLE -6
 STABILITY COEFFICIENTS m and n FOR $C'/\gamma H = 0.05$ & $D=1.00$
STABILITY COEFFICIENTS FOR EARTH SLOPES

ϕ'	SLOPE 2:1		SLOPE 3:1		SLOPE 4:1		SLOPE 5:1	
	m	n	m	n	m	n	m	n
10.0	0.913	0.563	1.181	0.717	1.469	0.910	1.733	1.069
12.5	1.030	0.690	1.343	0.878	1.688	1.136	1.995	1.316
15.0	1.145	0.816	1.506	1.043	1.904	1.353	2.258	1.567
17.5	1.262	0.942	1.671	1.121	2.117	1.565	2.317	1.825
20.0	1.380	1.071	1.840	1.387	2.333	1.776	2.783	2.091
22.5	1.500	1.202	2.014	1.568	2.551	1.989	3.055	2.365
25.0	1.624	1.338	2.193	1.757	2.778	2.211	3.336	2.651
27.5	1.753	1.480	2.380	1.952	3.013	2.444	3.628	2.948
30.0	1.888	1.630	2.574	2.157	3.261	2.693	3.934	3.259
32.5	2.029	1.789	2.777	2.370	3.523	2.961	4.256	3.585
35.0	2.178	1.958	2.990	2.592	3.803	3.253	4.597	3.927
37.5	2.336	2.138	3.215	2.826	4.803	3.574	4.959	4.288
40.0	2.505	2.332	3.451	3.671	4.425	3.926	5.344	4.669

TABLE –7
STABILITY COEFFICIENTS m and n FOR $C'/\gamma H = 0.05$ & $D=1.25$
STABILITY COEFFICIENTS FOR EARTH SLOPES

ϕ'	SLOPE 2:1		SLOPE 3:1		SLOPE 4:1		SLOPE 5:1	
	m	n	m	n	m	n	m	n
10.0	0.919	0.633	1.119	0.766	1.344	0.886	1.594	1.042
12.5	0.655	0.792	1.294	0.941	1.563	1.112	1.850	1.300
15.0	1.211	0.950	1.471	1.119	1.782	1.338	2.109	1.562
17.5	1.359	1.108	1.650	1.303	2.004	1.567	2.373	1.831
20.0	1.509	1.266	1.834	1.493	2.230	1.799	2.643	2.107
22.5	1.663	1.428	2.024	1.690	2.463	2.038	2.921	2.392
25.0	1.822	1.595	2.222	1.897	2.705	2.287	3.211	2.690
27.5	1.988	1.769	2.428	2.113	2.957	2.546	3.513	2.999
30.0	2.161	1.950	2.645	2.342	3.221	2.819	3.829	3.324
32.5	2.343	2.141	2.873	2.583	3.500	3.107	4.161	3.665
35.0	2.535	2.344	3.114	2.839	3.795	3.413	4.511	4.025
37.5	2.738	2.560	3.370	3.111	4.109	3.740	4.881	4.405
40.0	2.953	2.791	3.642	3.400	4.442	4.090	5.273	4.806

TABLE –8
STABILITY COEFFICIENTS m and n FOR $C'/\gamma H = 0.05$ & $D=1.5$
STABILITY COEFFICIENTS FOR EARTH SLOPES

ϕ'	SLOPE 2:1		SLOPE 3:1		SLOPE 4:1		SLOPE 5:1	
	m	n	m	n	m	n	m	n
10.0	1.022	0.751	1.170	0.828	1.343	0.974	1.547	1.108
12.5	1.202	0.936	1.376	1.043	1.589	1.227	1.829	1.399
15.0	1.383	1.122	1.583	1.260	1.835	1.480	2.112	1.690
17.5	1.565	1.309	1.795	1.480	2.084	1.734	2.398	1.983
20.0	1.752	1.501	2.011	1.705	2.337	1.993	2.690	2.280
22.5	1.943	1.698	2.234	1.937	2.597	2.258	2.990	2.585
25.0	2.143	1.903	2.467	2.179	2.867	2.534	3.302	2.902
27.5	2.350	2.117	2.709	2.431	3.148	2.820	3.626	3.231
30.0	2.568	2.342	2.964	2.696	3.443	3.120	3.967	3.577
32.5	2.798	2.580	3.232	2.975	3.753	3.436	4.326	3.840
35.0	3.041	2.832	3.515	3.269	4.082	3.771	4.707	4.325
37.5	3.299	3.102	3.817	3.583	4.431	4.128	4.112	4.753
40.0	3.574	3.389	4.136	3.915	4.803	4.507	5.343	5.171

Further extensions to the Bishop & Morgenstern slope stability tables:

The design charts for the effective stress stability analysis of slopes given by Bishop & Morgenstern (1960) are extended up to $C'/\gamma H=0.15$, $\phi'=20^\circ$ to 40° by Conner, O & Mitchell (1977) and Chandler & Peiris (1989).

TABLE -9
STABILITY COEFFICIENTS m and n FOR $C'/YH = 0.075$ & $D=1.00$

ϕ'	SLOPE 2:1		SLOPE 3:1		SLOPE 4:1		SLOPE 5:1	
	m	n	m	n	m	n	m	n
20.0	1.610	1.100	2.141	1.443	2.664	1.801	3.173	2.130
25.0	1.872	1.386	2.502	1.815	3.126	2.259	3.742	2.715
30.0	2.142	1.686	2.884	2.201	3.623	2.758	4.357	3.331
35.0	2.443	2.030	3.306	2.659	4.177	3.331	5.024	4.001
40.0	2.772	2.386	3.775	3.145	4.785	3.945	5.776	4.759

TABLE -10
STABILITY COEFFICIENTS m and n FOR $C'/YH = 0.075$ & $D=1.25$

ϕ'	SLOPE 2:1		SLOPE 3:1		SLOPE 4:1		SLOPE 5:1	
	m	n	m	n	m	n	m	n
20.0	1.688	1.285	2.071	1.543	2.492	1.815	2.954	2.173
25.0	2.004	1.641	2.469	1.957	2.972	2.315	3.523	2.730
30.0	2.352	2.015	2.888	2.385	3.499	2.857	4.149	3.357
35.0	2.728	2.385	3.357	2.870	4.079	3.457	4.831	4.043
40.0	3.154	2.841	3.889	3.428	4.729	4.128	5.603	4.830

TABLE -11
STABILITY COEFFICIENTS m and n FOR $C'/YH = 0.075$ & $D=1.50$

ϕ'	SLOPE 2:1		SLOPE 3:1		SLOPE 4:1		SLOPE 5:1	
	m	n	m	n	m	n	m	n
20.0	1.918	1.514	2.199	1.728	2.548	1.985	2.931	2.272
25.0	2.308	1.914	2.660	2.200	3.083	2.530	3.552	2.915
30.0	2.735	2.355	3.158	2.714	3.659	3.128	4.218	3.585
35.0	3.211	2.854	3.708	3.285	4.302	3.786	4.961	4.343
40.0	3.742	3.397	4.332	3.926	5.026	4.526	5.788	5.185

TABLE -12
STABILITY COEFFICIENTS m and n FOR $C'/YH = 0.100$ & $D=1.00$

ϕ'	SLOPE 2:1		SLOPE 3:1		SLOPE 4:1		SLOPE 5:1	
	m	n	m	n	m	n	m	n
20.0	1.841	1.143	2.421	1.472	2.982	1.815	3.549	2.157
25.0	2.102	1.430	2.785	1.845	3.358	2.303	4.131	2.743
30.0	2.378	1.714	3.183	2.258	3.973	2.830	4.751	3.372
35.0	2.692	2.086	3.612	2.715	4.516	3.359	5.426	4.059
40.0	3.025	2.445	4.103	3.230	5.144	4.001	6.187	4.831

TABLE –13
STABILITY COEFFICIENTS m and n FOR $C'/YH = 0.100$ & $D=1.25$

ϕ'	SLOPE 2:1		SLOPE 3:1		SLOPE 4:1		SLOPE 5:1	
	m	n	m	n	m	n	m	n
20.0	1.874	1.301	2.283	1.558	2.751	1.843	3.253	2.158
25.0	2.197	1.642	2.681	1.972	3.233	2.330	3.833	2.758
30.0	2.540	2.000	3.112	2.415	3.753	2.858	4.451	3.372
35.0	2.922	2.415	3.588	2.914	4.333	3.458	5.141	4.072
40.0	3.345	2.855	4.119	3.457	4.987	4.142	5.921	4.872

TABLE –14
STABILITY COEFFICIENTS m and n FOR $C'/YH = 0.100$ & $D=1.50$

ϕ'	SLOPE 2:1		SLOPE 3:1		SLOPE 4:1		SLOPE 5:1	
	m	n	m	n	m	n	m	n
20.0	2.079	1.528	2.387	1.742	2.768	2.014	3.158	2.285
25.0	2.477	1.942	2.852	2.215	3.297	2.542	3.796	2.927
30.0	2.908	2.385	3.349	2.728	3.881	3.143	4.468	3.614
35.0	3.385	2.884	3.900	3.300	4.520	3.800	5.211	4.372
40.0	3.924	3.441	4.524	3.941	5.247	4.542	6.040	5.200

TABLE –15
STABILITY COEFFICIENTS m and n FOR $C'/YH = 0.125$ & $D=1.00$

ϕ'	SLOPE 2:1		SLOPE 3:1		SLOPE 4:1		SLOPE 5:1	
	m	n	m	n	m	n	m	n
20.0	2.042	1.148	2.689	1.541	3.263	1.784	3.868	2.124
25.0	2.323	1.447	3.062	1.908	3.737	2.271	4.446	2.721
30.0	2.618	1.777	3.457	2.298	4.253	2.810	5.073	3.368
35.0	2.929	2.115	3.880	2.705	4.823	3.407	5.767	4.048
40.0	3.272	2.483	4.356	3.183	5.457	4.060	6.551	4.893

TABLE –16
STABILITY COEFFICIENTS m and n FOR $C'/YH = 0.125$ & $D=1.25$

ϕ'	SLOPE 2:1		SLOPE 3:1		SLOPE 4:1		SLOPE 5:1	
	m	n	m	n	m	n	m	n
20.0	2.054	1.324	2.492	1.579	2.983	1.861	3.496	2.167
25.0	2.377	1.671	2.894	1.993	3.481	2.379	4.078	2.753
30.0	2.727	2.042	3.324	2.431	4.009	2.916	4.712	3.405
35.0	3.110	2.451	3.801	2.928	4.586	3.500	5.414	4.128
40.0	3.542	2.913	4.338	3.494	5.237	4.161	6.207	4.945

TABLE –17
STABILITY COEFFICIENTS m and n FOR $C'/YH = 0.125$ & $D=1.50$

ϕ'	SLOPE 2:1		SLOPE 3:1		SLOPE 4:1		SLOPE 5:1	
	m	n	m	n	m	n	m	n
20.0	2.234	1.545	2.565	1.749	2.963	2.004	3.400	2.287
25.0	2.638	1.972	3.028	2.229	3.500	2.550	4.019	2.913
30.0	3.072	2.425	3.529	2.749	4.083	3.149	4.692	3.598
35.0	3.549	2.923	4.084	3.324	4.727	3.813	5.436	4.362
40.0	4.089	3.485	4.712	3.980	5.456	4.566	6.278	5.226

TABLE –18
STABILITY COEFFICIENTS m and n FOR $C'/YH = 0.150$ & $D=1.00$

ϕ'	SLOPE 2:1		SLOPE 3:1		SLOPE 4:1		SLOPE 5:1	
	m	n	m	n	m	n	m	n
20.0	2.261	1.170	2.895	1.448	3.579	1.806	4.230	2.159
25.0	2.536	1.462	3.259	1.814	4.052	2.280	4.817	2.765
30.0	2.836	1.791	3.657	2.245	4.567	2.811	5.451	3.416
35.0	3.161	2.153	4.098	2.721	5.137	3.408	6.143	4.117
40.0	3.512	2.535	4.597	3.258	5.782	4.083	6.913	4.888

TABLE –19
STABILITY COEFFICIENTS m and n FOR $C'/YH = 0.150$ & $D=1.25$

ϕ'	SLOPE 2:1		SLOPE 3:1		SLOPE 4:1		SLOPE 5:1	
	m	n	m	n	m	n	m	n
20.0	2.229	1.334	2.701	1.600	3.225	1.873	3.780	2.182
25.0	2.560	1.692	3.107	2.015	3.724	2.384	4.363	2.769
30.0	2.909	2.065	3.542	2.464	4.262	2.941	5.995	3.406
35.0	3.295	2.475	4.018	2.946	4.846	3.534	5.697	4.129
40.0	3.728	2.938	4.556	3.509	5.498	4.195	6.490	4.947

TABLE –20
STABILITY COEFFICIENTS m and n FOR $C'/YH = 0.150$ & $D=1.50$

ϕ'	SLOPE 2:1		SLOPE 3:1		SLOPE 4:1		SLOPE 5:1	
	m	n	m	n	m	n	m	n
20.0	2.394	1.550	2.748	1.756	3.174	2.020	3.641	2.308
25.0	2.798	1.978	3.212	2.237	3.711	2.561	4.259	2.924
30.0	3.236	2.441	3.718	2.758	4.293	3.156	4.931	3.604
35.0	3.715	2.940	4.269	3.333	4.938	3.819	5.675	4.364
40.0	4.255	3.503	4.896	3.983	5.667	4.569	6.517	5.228

FIELD COMPACTION TRIAL

1.0 General:

Field compaction trial is carried out to economise in compaction aspect of earthwork while achieving desired level of density based on Lab tests (Heavy compaction test, IS:2720 (Pt-8) and relative density test, IS:2720 (Pt -14). However, type of roller has to be decided depending on type of soil to be compacted in execution of earthwork.

2.0 Determination of compaction efficiency

The increasing trend of density with increase in number of passes of a compactor tends to diminish gradually and a 'diminishing return stage' is reached. This will determine the type of compactor, optimum thickness of lift, corresponding water contents and number of roller passes.

3.0 Methodology for conducting field compaction trial includes following steps:

Step 1: Construct a test ramp of about 30m long, 10m wide & 0.15m thick on one end & 0.55m on other end, preferably at the construction site, over a level ground surface clear of bushes, depressions etc under nearly identical conditions (Fig 1 of Annexure –IV).

Step 2: Divide the ramp equally into desired no., say, four segments, longitudinally of about 2.5m width (more than width of roller). Each strip will be used for conducting trial at specific moisture content, viz. OMC (Lab test value), OMC \pm 4% and (PL - 2%) etc.

Note: Experience shows that most suitable water content falls within a small range of 3% below to 1% above the OMC for most of the- soil.

Step 3: Start compaction trial on first segment at a particular moisture content (step 2).

Step 4: Fix four number sampling points on this strip at locations where layer thickness of about 0.225, 0.30, 0.375 & 0.450m are to be obtained after rolling.

Step 5: Collect samples around the sampling points (Step 4). Determine moisture content by any suitable standard method

Step 6: Compare the moisture content with that of the relevant desired moisture content (Step-3).

Step 7 Wait for natural drying if moisture content is on higher side or sprinkle appropriate amount of water uniformly followed by ploughing etc. and leave for 5 to 30 minutes depending on type of soil, in case the moisture content is on lower side (Step 3).

Step 8 Determine moisture content once again at sampling points before rolling. Observations of determination of moisture content are recorded as per Table-1 of Annexure-IV.

Step 9 Roll the strip and measure the dry density (by any standard method) of the soil after every two passes commencing from four roller passes. The observations are recorded as per table-2.

Note: Measurement of dry density and moisture content are taken after removing top 5 cm layer of earth with least possible disturbance. If the layer thickness is small, density ring should be used.

Step 10: Carry out testing on each strip at different specific moisture content as for first strip explained above. Compile the results of trial of all strips as per table -3.

Step 11. From these test results, two sets of graph are plotted:

First set of graph(Fig 2) - Dry density vs no., of roller passes for each water content and lift thickness. For each lift, there would be four (depending on range of moisture content chosen) curves for different moisture content.

Second set of graph (Fig 3): Maximum dry density vs moisture content for each lift thickness.

Step 12: Fig 3 will give field moisture content, maximum attainable field dry density and optimum lift thickness. From these field values minimum no. of passes of particular roller are read from Fig 2.

COMPACTION EQUIPMENT DATA

Project..... Location.....
Date.....

Item		Roller - 1	Roller - 2	Roller - 3
Type of Roller				
Gross weight (tonnes)				
Drum Dimension (Roller Type)	Width (mm)			
	Diameter (mm)			
Foot (Sheep foot Type)	Type			
	Number			
	Length (mm)			
	Area (mm ²)			
Contact Area (cm ²) (Sheep foot/Pneumatic Tyred/Vibratory Plate Type)				
Tyre Inflation Pressure(KG/CM ²)				
Nominal Amplitude(MM)				
Frequency(Hz)				
Dynamic Force(KG)				
Operational Speed(KMPH)				
Static Linear Loads(KG/CM)				
Contact Pressure(KG/CM ²)				

LIST OF EQUIPMENT FOR FIELD TRIALS/MONITORING

S.No.	Equipment	No. Reqd.	No. available
1.	Pan balance with weights (50g to 500g)	1 Set	
2.	Physical balance with weights(1mg to 100mg)	1 Set	
3.	Core cutter with dolly and hammer	4 Sets	
4.	Spatula	4 Nos.	
5.	Frying Pan	1 No.	
6.	Containers plastic (about 500g capacity)	8 Nos.	
7.	Enamel plates(1cm Dia.)	16 Nos.	
8.	Uniform clean sand (Ottawa Sand)	10 Nos.	
9.	Measuring tape (2.0 M)	1 No.	
10.	Measuring tape (15 M/30M)	1 No.	
11.	Kerosene oil stove	1 No.	

Signature of _____ Monitoring Official _____ Name _____ Designation _____	Signature of _____ Project Official _____ Name _____ Designation _____
--	---

TABLE -1 FIELD COMPACTION TRIAL OBSERVATION

Project _____

Date _____

Location _____

Strip No.	Location on the ramp	Moisture content before watering				Moisture content after adding the water			
		Container No.	Weight of wet soil.(gms)	Weight of dry soil.(gms)	Moisture content(%)	Container No.	Weight of wet soil.(gms)	Weight of dry soil.(gms)	Moisture content(%)
1	2	3	4	5	6	7	8	9	10
J	1								
	2								
	3								
	4								
K	1								
	2								
	3								
	4								
L	1								
	2								
	3								
	4								
M	1								
	2								
	3								
	4								

Signature of Monitoring official _____
 Name _____
 Designation _____
 Date _____

Signature of Project Official _____
 Name _____
 Designation _____
 Date _____

TABLE -2 FIELD COMPACTION TRIAL OBSERVATION

Project _____
 RIP _____ OMC _____ %

Location: _____ Date _____
 MDD _____ gms/cc Volume of core cutters: _____ C.C.

No.of roller passes	Location of the Ramp	In-situ bulk density					Moisture content				Dry density of soil	Percent of MDD	Remark
		Core cutter No.	Wt. Of empty core cutter (gm)	WT of wet soil with core cutter (gm)	WT of wet soil (gm)	Bulk density of soil (gm/cc)	Container No.	WT of wet soil (gms)	WT of dry soil (gms)	Moisture content (%)			
1	2	3	4	5	6	7	8	9	10	11	12	13	14
4	1												
	2												
	3												
	4												
6	1												
	2												
	3												
	4												
10	1												
	2												
	3												
	4												
12	1												
	2												
	3												
	4												

Signature of monitoring official _____
 Name _____
 Designation _____

Signature of project official _____
 Name _____
 Designation _____

TABLE-3 FIELD COMPACTION TRIAL-COMPUTATION SHEET

S. No	Lift thickness (mm)	Moisture content %	Dry density of soil(gm/cc)								Remarks
			Nos. of the roller passes								
			4	6	8	10	12	14	16	18	
1.	225										
2.	300										
3.	375										
4.	450										
5.	525										
6.	600										

Computed by _____ **Checked by** _____
Name _____
Name _____
Designation _____
Designation _____
Date _____ **Date** _____

Project _____ **Location** _____

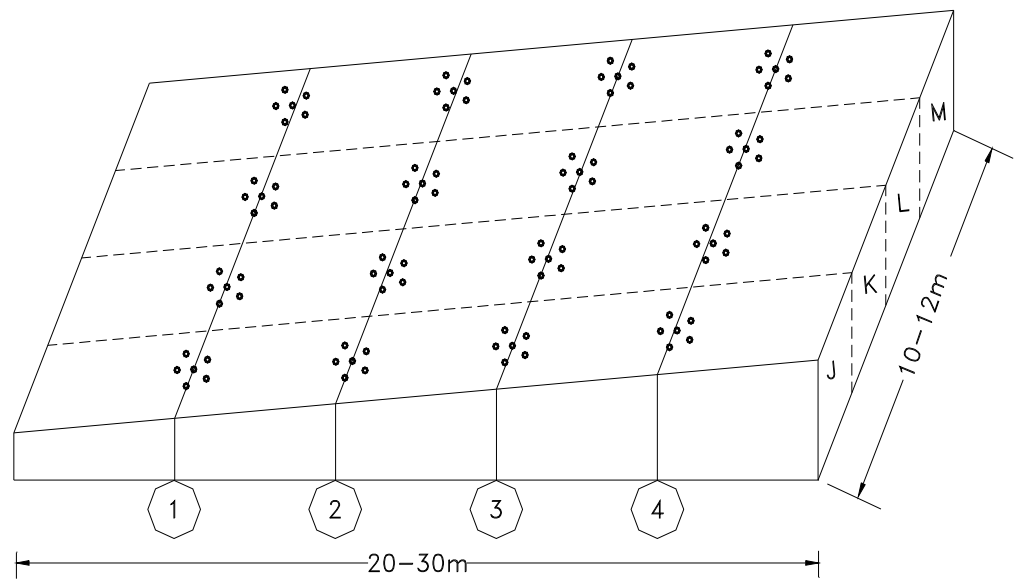

RAMP OF EARTH FOR COMPACTION TRIALS IN THE FIELD

- SAMPLING - J K L M
- MOISTURE CONTENT (%) (WITH VARIATIONS OF $\pm 2\%$) - OMC-4 OMC OMC+4 PL-2
- SAMPLING POINTS - $J_1, J_2, J_3, J_4 ; K_1, K_2, K_3, K_4 ; L_1, L_2, L_3, L_4 ; M_1, M_2, M_3, M_4,$
- THICKNESS IN MM. - 225, 300, 375 & 450
- NO. OF TIMES FOR OBSERVATIONS - 6(SIX), (AFTER INTERVAL OF 4,6,8,10,12 & 14 PASSES OF ROLLER)
- TOTAL NO. OF OBSERVATIONS - $4 \times 4 \times 6 = 96$

FIG. 2 OF 3 OF ANNEXURE-IV

NAME OF PROJECT _____	OMC-4	○ ————— ○
LOCATION _____	OMC	● ————— ●
	OMC+4	△ ————— △
	PL-2	▲ ————— ▲

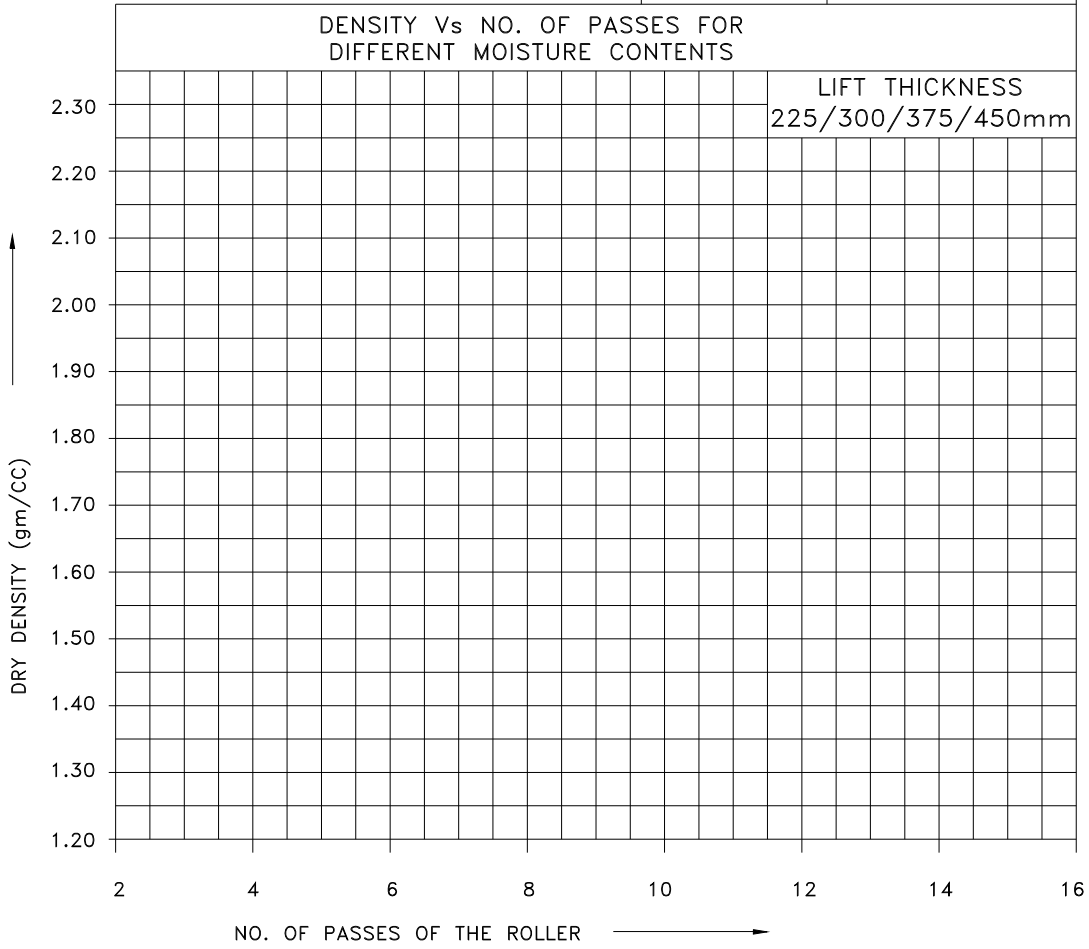

OFFICIALS - IN - CHARGE	QUALITY CONTROL OFFICIALS
SIGNATURE _____	SIGNATURE _____
NAME OF OFFICER _____	NAME OF OFFICER _____
DESIGNATION _____	DESIGNATION _____
DATE _____	DATE _____

NAME OF PROJECT	LIFT	NOTATION
LOCATION	225mm	○ — ○
	300mm	● — ●
	375mm	△ — △
	450mm	▲ — ▲

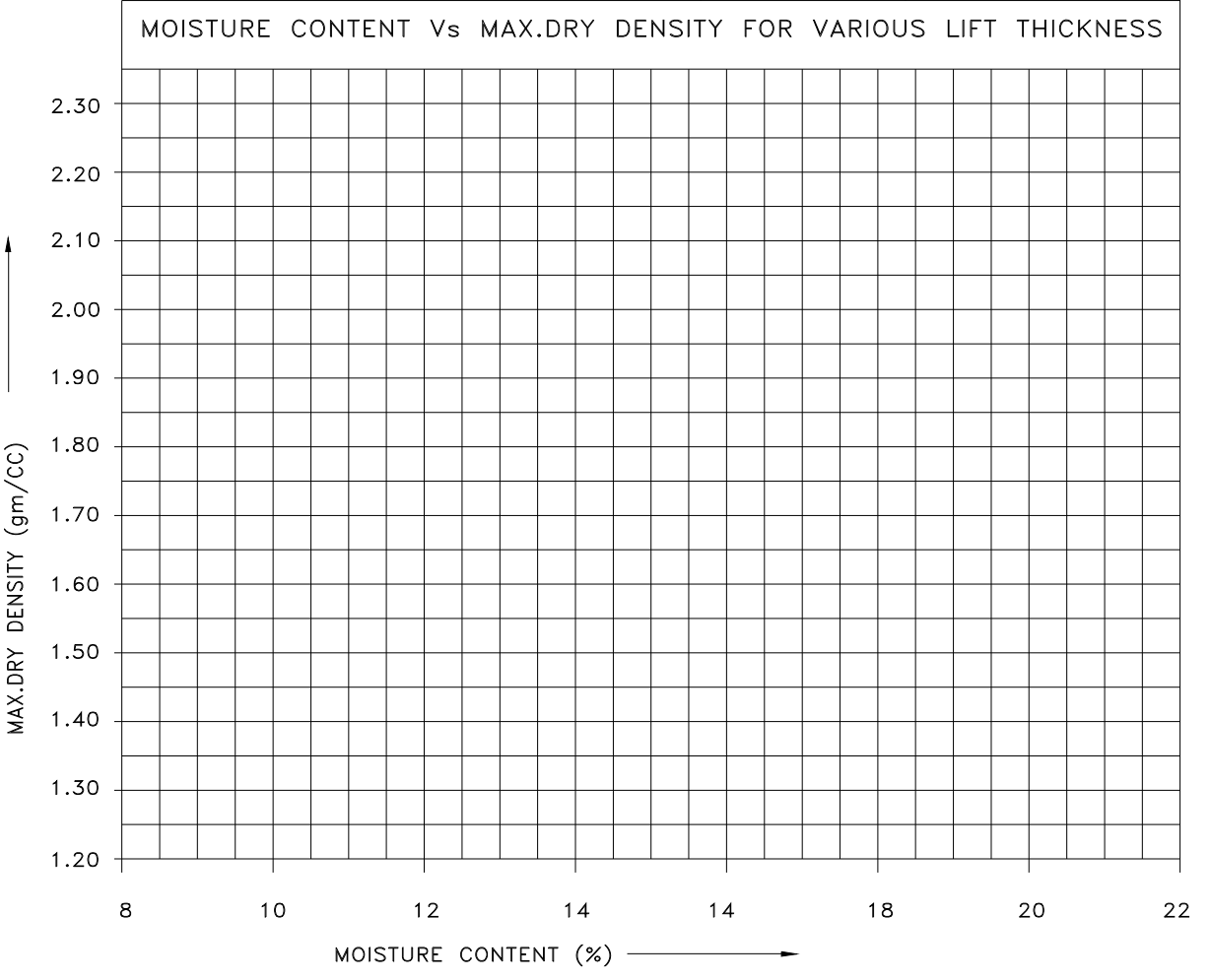

OFFICIALS – IN – CHARGE	QUALITY CONTROL OFFICIALS
SIGNATURE _____	SIGNATURE _____
NAME OF OFFICER _____	NAME OF OFFICER _____
DESIGNATION _____	DESIGNATION _____
DATE _____	DATE _____
SIGNATURE _____	SIGNATURE _____
NAME OF OFFICER _____	NAME OF OFFICER _____
DESIGNATION _____	DESIGNATION _____
DATE _____	DATE _____

Typical Compaction Characteristics for natural soils, rocks and artificial materials (Ref: BS: 6031 – 1981, Table 4)

Material (1)	Major divisions (2)	Subgroups (3)	Suitable type of compaction plant (4)	Maximum number of passes for satisfactory compaction (5)	Maximum thickness of compacted layer (mm) (6)	Remarks (7)
Rock-like materials	Natural rocks	All rock fill (except chalk)	Heavy vibratory roller not less than 180 kg per 100 mm of roll Grid roller not less 180 kg per 100 mm of roll Self-propelled tamping rollers	4 to 12	500 to 1500 depending on plant used	If well graded or easily broken down then this can be classified as a coarse-grained soil for the purpose of compaction. The maximum diameter of the rock fragment should not exceed two third of the layer thickness.
		Chalk	See remarks	3	500	This material can be very sensitive to weight and operation of compacting effort and spreading plant. Less compactive effort is needed than with other rocks.
Artificial	Waste material	Burnt and unburnt colliery shale	Vibratory roller Smooth wheeled roller Self-propelled tamping roller	4 to 12 depending on weight of plant	300	
		Pulverized fuel ash	Vibratory roller Self-propelled tamping roller Smooth wheeled roller Pneumatic tired roller			Includes lagoon and furnace bottom ash
		Broken concrete, bricks, steelworks, slag , etc.	Heavy vibratory roller Self-propelled tamping roller Smooth wheeled roller			Non-processed sulphide brick slag should be use with caution

(continued)

Guidelines for Earthwork in Railway Projects

(1)	(2)	(3)	(4)	(5)	(6)	(7)
Coarse-grained soils	Gravel sand, gravelly soils	Well graded gravel and gravel/sand mixture: little or no fines Well graded gravel/ sand mixtures with excellent clay binder Uniform gravel: little or no fines Poorly graded gravel and gravel/sand mixtures: little or no fines Gravel with excess fines, silty gravel, clayey gravel, poorly graded gravel/ sand/clay mixtures	Grid roller over 540 kg per 100mm of roll Pneumatic tired over 2000 kg per wheel Vibratory plate compactor over 1100 kg/sq.m. of base plate Smooth wheel roller Vibratory roller Vibro-rammer Self-propelled temping roller	3 to 12 depending on type of plant	75 to 275 depending on type of plant	
	Sand and sandy soils	Well graded sands and gravelly sands; little or no fines Well graded sands with excellent clay binder				
	Uniform sands and gravels	Uniform gravels; little or no fines Uniform sands; little or no fines Poorly graded sands; little or no fines Sands with fines, silty sands, clayey sands, poorly graded sand/clay mixtures	Smooth wheeled roller below 500kg per 100mm of roll Grid roller below 540kg per 100mm of rolling Pneumatic tired roller below 1500kg per wheel Vibratory roller Vibrating plate compactor Vibro-tamper	3 to 16 depending on type of plant	75 to 300 depending on type of plant	

Guidelines for earthwork in Railway Projects

(1)	(2)	(3)	(4)	(5)	(6)	(7)	
Fines soils	Soils having low plasticity	Silts (inorganic) and very fine sands, rock flour, silty or clayey fine sands with slight plasticity Clayey silts (inorganic) Organic silts of low plasticity	Sheepsfoot roller Smooth wheeled roller Pneumatic tired roller Vibratory roller over 70 kg per 100 mm of roll Vibratory plate compactor over 1400 kg/sq.m of base plate Vibro-tamper Power rammer	4 to 8 depending on type of plant	100 to 450 depending on type of plant	If water content is low, it may be preferable to use vibratory roller. Sheepsfoot rollers are best suited to soils at water contents below their plastic limit.	
	Soils having medium plasticity	Silty and sandy clays (inorganic) of medium plasticity Clays (inorganic) of medium plasticity					
		Organic clays of medium plasticity				Generally unsuitable for Earthworks	
	Soils having high plasticity	Micaceous or diatomaceous fine sandy and silty soils, plastic silts Clay (inorganic) of high plasticity, fat clays					Should only be used when circumstances are favourable.
		Organic clays of high plasticity					Should not be used for earthworks

Note: The information in this table should be taken only as a general guide. Field trials for compaction should be conducted for working out optimum layer thickness and number of roller passes for the type of compaction equipment being used. Compaction of mixed soils should be based on that subgrade requiring most compactive effort.

PROFORMA NO 1

Details of Borrow soil/ Formation subgrade

S. no	Date of taking sample	Location of subgrade sample Chainage/km	Soil type				Soil classification	LL	PL	Whether of dispersive nature	Suitable/ Non suitable,	Signature and name of Rly official	Signature and name of contractor	Remarks
			Gravel %	Sand %	Silt %	Clay %								
1	2	3	4	5	6	7	8	9	10	11	12	13	14	

PROFORMA NO 2

QUALITY OF BLANKET MATERIAL

1. Height of bank
2. Type of material: Crusher / Blending

S.no	Date of taking sample	Location of blanket layer Ch/km	Soil type			Fines Plastic/non plastic %	C _u	C _c	Quality Non suitability, skip grading etc	Abrasion Value (only for axle load > 22.5 t)	Signature and name of Rly official	Signature and name of contractor	Remarks
			Gravel %	Sand %	Silt + Clay % (passing 75 mic)								
1	2	3	4	5	6	7	8	9	10	11	12	13	14

PROFORMA FOR FIELD COMPACTION RECORD

PROFORMA No 3

Chainage / km from to.....
 Height of bank:
 Type of roller being used:

Soil Classification:
 OMC:
 Lab. MDD/ Field Trial MDD:

CORE CUTTER METHOD

Date of Laying	Layer no.	location coordinate for check	Placment moisture content (%)	No. of passes	Wt.of core cutter+wet soil (g)	Wt.of core cutter (g)	Wt of wet soil (g)	Vol.of core cutter (cc)	Bulk density, γ_b (g/cc)
1	2	3	4	5	6	7	8	9	10

Moisture content of compacted layer (%)	Dry Density, γ_d (g/cc)	Degree of compaction (%)	Sig. And name of Rly officer	Sig.and name of contractor	Remarks
11	12	13	14	15	16

Note: In case of compaction of blanket material, percentage of fines should also be mentioned in a column. The above format is taken from Appendix A (page 8) of IS: 2720 Pt 29 - 1975

PROFORMA FOR FIELD COMPACTION RECORD

Proforma No. 4

Chainage /km from to.....
 Height of bank:

Soil Classification:
 γ max (from lab)
 γ min (from lab)

SAND REPLACEMENT METHOD

Location	Bulk density of sand, (γ_s) g/cum	Wt of wet soil from hole, W_w (g)	Wt of Cylinder + Sand, before pouring W_1 (g)	Wt of sand + Cylinder after pouring W_2 (g)	Mean weight of sand in cone W_3 (g)	Wt of sand in hole $W_b = W_1 - W_2 - W_3$	Bulk Density of soil $\gamma_b = (W_w / W_b) * \gamma_s$	Moisture content (w), %	Dry Density of soil $\gamma_d = \gamma_b / (1 + w)$	Relative Density I_D	Sign. and name of Rly Official	Sign and name .of contractor	Remarks
----------	--	-------------------------------------	---	---	---------------------------------------	--	--	-------------------------	---	------------------------	--------------------------------	------------------------------	---------

Note: Relative density, I_D , is worked out as , $I_D = \frac{\gamma_d - \gamma_{d \min}}{\gamma_d - \gamma_{d \max}}$

The above format is taken from appendix A (Page 18 and 19) of IS: 2720 (Pt 28)1974

Summary of Quality control tests of Earth Work

Item/ Material	tests to be conducted	Testing equipment to be used	IS Code Ref.	Frequency of test	Sampling	Acceptance Criteria	Purpose of test
i) Borrow material	Soil classification, OMC, MDD, NMC, NDD	Sieve, hydrometer, Atterberg limit apparatus, modified Proctor mould, oven, balance, weight, distilled water, dispersing agent.	IS: 2720 Releva nt part	Minimum one test for every 5000 cum or change of strata wherever is earlier	Disturbed sample	Should not be “unsuitable type “ as given in para 5.1	- Suitability of material -To decide OMC & MDD
ii) Blanket material	Soil classification, Particle size distribu- tion curve,% fine, Cu, Cc, γ_{max} , γ_{min} , or OMC & MDD	as above plus RD apparatus	-do-	Minimum one test for 500 cum	Sampling from material placed at formation	Should conform to specification given as per para 4.3.4.1	Suitability of material
iii) Compa- cted earth (Sub-grade)	Field dry density	Core Cutter & Sand replacement Apparatus, Nuclear Moisture- Density Gauge, Continuous compaction recorder mounted in roller.	IS - 2720 Releva nt part	a) Min. one test in each compacted layer for every 200 sqm in top 1 m of subgrade b) Min. one test in each compacted layer for every 500 sqm below top 1 m of subgrade c) Min. one test in each compacted layer of blanket for every 200sqm	Sampling as per para 7.2.2.1(a)	98% of Lab. MDD as per Heavy Compaction test or as decided from field compaction trial or 70% of Density index for soils having fines < 5%	To ascertain degree of compaction
iv) Blanket Layer	Field dry density	-do-			Sampling as per para 7.2.2.1(a)		To ascertain degree of compaction

Guidelines for Earthwork in Railway Projects

SALIENT FEATURES OF VIBRATORY ROLLERS MANUFACTURED IN INDIA

ANNEXURE - VIII

(page 1 Of 1)

MAKE	MODEL No.	OPERATING WEIGHT (Kg)	DRUM DETAIL			NORMAL AMPLITUDE (mm)	VIBRATING FREQUENCY (Hz)	REMARKS
			DRUM WIDTH (mm)	AXLE LOAD (T)				
				FRONT	REAR			
ESCORTS	EC 5250 STD	9350	2130	5.050	4.300	1.72	30	
	EC 5250 D	9550	2130	5.250	4.300	1.72	30	It is used for better gradeability.
	EC 5250 PD	10500	2130	6.650	4.300	1.53	30	It is used for better gradeability & breaking clods.
	HD 85	9300	1680	4.650	4.650	1.27/0.75	0-30/42	
GREAVES BOMAG	BW 212-D-2(2A)	10424	2100	6.463	3.961	1.67	40/31	It is used for better gradeability.
	BW 212-PD-2	10879	2100	6.201	4.678	1.5	30	It is used for better gradeability & breaking clods.
L&T	1104 STD	11150	2330	5.770	5.380	1.6/0.6	28/36	
	1104 D	11150	2330	5.900	5.535	1.6/0.6	28/36	It is used for better gradeability.
	1104 PD	11835	2330	6.300	5.535	1.6	28	It is used for better gradeability & breaking clods.
INGERSOLL-RAND	ISD-100 STD	10740	2135	6.210	4.535	1.7	0-30	
	ISD-100 D	10830	2135	6.295	4.535	1.7	0-30	It is used for better gradeability.
	ISD-100 F	11740	2135	7.205	4.535	1.41	0-30	

NOTE : The rollers indicated above can also be used in Static mode. The list includes rollers manufactured by reported firms only.

LEGEND: STD = Standard Type, D = Drum Type & PD = Pads+ Drum Type

LIST OF RELEVANT I.S. CODES

S. NO.	I.S. CODE NO.	DISCRIPTION
1.	IS: 2720 -1983 Part-1 (Revision 2)	Methods of test for soils. Preparation of dry soil samples for various tests.
2.	IS: 2720-1973 Part-2 (Revision 2)	Methods of test for soils. Determination of water content
3.	IS: 2720-1964 Part-3 Section 1	Methods of test for soils. Determination of specific gravity. Fined grained soils (Reaffirmed 1987)
4.	IS: 2720-1980 Part-3 Section 2 (Revision 1)	Methods of test for soils. Determination of specific gravity. Section 2 Fine, Medium and coarse-grained soils. (Reaffirmed 1987)
5.	IS: 2720-1985 Part-4 (Revision 2)	Methods of test for soils. Grain size analysis.
6.	IS: 2720-1985 Part-5 (Revision 2)	Methods of test for soils. Determination of liquid and plastic limits.
7.	IS: 2720-1972 Part –6 (Revision 1)	Methods of test for soils. Determination of shrinkage factors.
8.	IS: 2720-1980 Part-7 (Revision 2)	Methods of test for soils. Determination of water content-dry density relation using light compaction.
9.	IS: 2720-1974 Part-8 (Revision 1)	Methods of test for soils. Determination of water content-dry density relation using heavy compaction.
10.	IS: 2720-1971 Part-9	Methods of test for soils Determination of dry density –moisture content relation by constant weight of soil method. (Reaffirmed 1990)
11.	IS: 2720-1991 Part-10 (Revision 2)	Methods of test for soils. Determination of unconfined compressive strength.
12.	IS: 2720-1971 Part-11	Methods of test for soils. Determination of the shear strength parameters of a specimen tested in unconsolidated undrained triaxial compression without the measurement of pore water pressure. (Reaffirmed 1990)
13.	IS: 2720-1981 Part-12	Methods of test for soils. Determination of shear strength parameters of soil from consolidated undrained triaxial compression test with measurement of pore water pressure.

Guidelines for Earthwork in Railway Projects

14.	IS: 2720-1986 Part-13 (Revision 2)	Methods of test for soils. Direct shear test
15.	IS: 2720-1983 Part-14 (Revision 1)	Methods of test for soils. Determination of density index (Relative density) of cohesionless soils.
16.	IS: 2720-1965 Part-15	Methods of test for soils. Determination of consolidation properties.
17.	IS: 2720-1987 Part-16 (Revision 2)	Methods of test for soils. Methods of test for soil. Laboratory determination of CBR.
18.	IS: 2720-1966 Part-17	Methods of test for soils. Laboratory determination of permeability. (with amendment No. 1)
19.	IS: 2720-1964 Part-18	Methods of test for soils. Determination of field moisture equivalent.
20.	IS: 2720-1964 Part-19	Methods of test for soils. Determination of centrifuge moisture equivalent.
21.	IS: 2720-1966 Part-20	Methods of test for soils. Determination of linear shrinkage. (with amendment No. 1)
22.	IS: 2720-1977 Part-21 (Revision 1)	Methods of test for soils. Determination total soluble solids.
23.	IS: 2720-1972 Part-22 (Revision 1)	Methods of test for soils. Determination of organic matter.
24.	IS: 2720-1976 Part-23 (Revision 1)	Methods of test for soils. Determination of calcium carbonate.
25.	IS: 2720-1976 Part-24 (Revision 1)	Methods of test for soils. Determination of cation exchange capacity.
26.	IS: 2720-1982 Part-25 (Revision 1)	Methods of test for soils. Determination of silica sesquioxide ratio.
27.	IS: 2720-1973 Part-26(Revision 1)	Methods of test for soils. Determination of pH value.
28.	IS: 2720-1977 Part-27 (Revision 1)	Methods of test for soils. Determination of total soluble sulphate.
29.	IS: 2720-1974 Part-28 (Revision 1)	Methods of test for soils. Determination of dry density of soils in -place by the sand replacement method.
30.	IS: 2720-1975 Part29 (Revision 1)	Methods of test for soils. Determination of dry density of soils in- place by the core cutter method.

Guidelines for Earthwork in Railway Projects

31.	IS: 2720-1980 Part-30 (Revision 1)	Methods of test for soils. Laboratory vane shear test.
32.	IS: 2720-1969 Part-31	Methods of test for soils. Field determination of california bearing ratio.
33.	IS: 2720-1970 Part-32	Methods of test for soils. North Dakota cone test. (Withdrawn)
34.	IS: 2720-1971 Part-33	Methods of test for soils. Determination of the density in- place by the ring and water replacement method.
35.	IS: 2720-1972 Part-34	Methods of test for soils. Determination of dry density of soil in- place by rubber balloon method.
36.	IS: 2720-1974 Part-35	Methods of test for soils. Part-35 Measurement of negative pore water pressure.
37.	IS: 2720-1987 Part-36 (Revision 1)	Methods of test for soils. Part-36 Laboratory determination of permeability of granular soils (constant head).
38.	IS: 2720-1976 Part-37	Methods of test for soils. Part-37 Determination of sand equivalent value of soils and fine aggregates.
39.	IS: 2720-1976 Part-38	Methods of test for soils. Part-38 Compaction control test (Hilf method).
40.	IS: 2720-1977 Part-39 Section 1	Methods of test for soils. Direct shear test for soils containing gravel. Section 1 Laboratory test.
41.	IS: 2720-1979 Part-39 Section 2	Methods of test for soils. Direct shear test for soils containing gravel. Section 2 in-situ shear test.
42.	IS: 2720-1977 Part-15	Methods of test for soils. Determination of free swell index of soils.
43.	IS: 2720-1977 Part-16	Methods of test for soils. Measurement of swelling pressure of soils.
44.	IS: 2810-1979 Revision 1	Glossary of terms relating to soil dynamics.
45.	IS: 4434-1978 Revision 1	Code of practice for in-situ vane shear test for soils.
46.	IS: 4968-1976 Part 1 Revision 1	Method of subsurface sounding for soils. Part I Dynamic method using 50mm cone without bentonite slurry.
47.	IS: 4968-1976 Part 2 Revision 1	Method of subsurface sounding for soils. Part II Dynamic method using cone and bentonite slurry.
48.	IS: 4968-1976 Part 3 Revision 1	Method of subsurface sounding for soils. Part III Static cone penetration test.
49.	IS: 5249-1969	Method of test for determination of in-situ dynamic properties of soils.
50.	IS: 460-1985	Specification of test sieves.

Guidelines for Earthwork in Railway Projects

	Part 1 Revision 3	Wire cloth test sieves.
51.	IS: 460-1985 Part 2 Revision 3	Specification of test sieves. Perforated plate test sieve.
52.	IS: 460-1985 Part 3 Revision 3	Specification of test sieves. Part III Methods of examination of apertures of test sieves.
53.	IS: 1498-1970 Revision 1	Classification and identification of soils for general engineering purposes.
54.	IS: 1607-1977	Methods for test sieving.
55.	IS: 4616-1968	Specification for SheepsFoot roller.
56.	IS: 5421-1981 Revision 1	Glossary of terms relating to test sieves and tests sieving.
57.	IS: 5500-1969	Specification for vibratory roller.
58.	IS: 5501-1969	Specification for pneumatic tyred roller.
59.	IS: 5502-1969	Specification for smooth-wheeled diesel road roller.
60.	IS: 1888-1982 Revision 2	Method of load test on soils.
61.	IS: 1892-1979	Code of practice for site investigations for foundations. (With amendment no. 1)
62.	IS: 2131-1981 Revision 1	Method for standard penetration test for soils. (Reaffirmed 1987)
63.	IS: 2132-1972 Revision 1	Code of practice for thin walled tube sampling of soils.
64.	IS: 2132-1972 Revision 1	Code of practice for thin walled tube sampling of soils.
65.	IS: 10074-1982	Specification for compaction mould assembly for light and heavy compaction test of soils.
66.	IS: 10077-1982	Specification for equipment for determination of shrinkage factors.
67.	IS: 10379-1982	Code of practice for field control of moisture and compaction of soils for embankment and sub-grade.
68.	IS: 10837-1984	Specification for moulds and accessories for determination of density index (relative density) of cohesionless soils.
69.	IS: 11196-1985	Specification for equipment for determination of liquid limit of soils-cone penetration method.
70.	IS: 11229-1985	Specification for mould assembly for determination of permeability of soils.
71.	IS: 11209-1985	Specification for shear box for testing of soils.
72.	IS: 4081	Safety Code for Blasting and Related Drilling Operations
73.	IS: 3764	Safety Code for Excavation Work

Note: Latest version of BIS codes shall be referred.

LIST OF EQUIPMENTS FOR FIELD LAB

S N.	DESCRIPTION OF EQUIPMENT	REFERENCE OF I.S. CODE	UNIT
1	IS set of sieves with base & top lid 20mm, 19mm,10mm, 4.75mm, 2 mm 600mic, 425mic, 212mic, 75mic,.	ISS-460	2 sets
2	Hand operated sieve shaker for above sieves.		1 no.
3	BALANCE i) Pan balance - 10 kg capacity (with 1.0 gm Least Count) ii) Electronic balance - 500 gm capacity (with 0.1 gm Least Count)		1 no. 1 no.
4	Field density apparatus complete. a) sand replacement b) core cutter with dolly	2720-1974 part-XXVIII 2720-1975 part-XXIX	2 sets 5 sets
5	Modified heavy Proctor density apparatus full unit.	2720 part-8-1983	2 sets
6	Liquid Limit apparatus hand operated with counter & grooving tools.	2720 part-V-1985	2 sets
7	Shrinkage limit apparatus		1 no.
8	Stainless steel spatula - 25cm long		2 no.
9	Porcelain bowl for LL - 15cm dia.		3 no.
10	Aluminium dish with lid – 5cm dia.		4 no.
11	Wash bottle - 1 lit. capacity 500ml capacity		6 no.
12	Glass plate 10mm thick 50x50 cm		2 no.
13	Ground glass 5mm thick 50x50 cm		2 no.
14	Enameled trays 45x30cm 20x20cm		3 no. 3 no.
15	enameled plates 6inch dia 8 inch dia. 10 inch dia.		10 no. 10 no. 10 no.
16	Frying pans		3 no.
17	Stove janta		2 no.
18	Straight edge 300mm long		3 no.

LIST OF EQUIPMENT FOR FIELD LAB

S. NO.	DESCRIPTION OF EQUIPMENT	REFERENCE OF I.S. CODE	UNIT
19	Grain size analyser of fines a) Hydrometer b) Thermometer 0 to 50 c c) Glass cylinder 1000cc capacity with 60mm dia.	IS-2720 part-4-1985	2 no. 2 no. 5 no.
20	Desiccators as IS -6128		2 no.
21	Can of 10 litre capacity for distilled water Wooden mortar and pestle.		3 no.
22	Specific gravity test apparatus.		1 no.
23	Density bottle-50ml capacity Glass cylinder 100 cc capacity (for 1		2 no. 2 no.
24	Free Swell index test)		
25	Oven- thermostatically controlled to maintain a temperature 105-110c		1 no.
	<u>Consumable Item</u>		
	Sieve brush		
26	Wire brush		
27	Sodium carbonate		
28	Sodium hexa meta phosphate.		
29	Kerosene		
30	Mercury		
	<u>Additional Equipment</u>		
31	Hand auger 150mm dia with extension rod		
32	Sampling tube 100mm dia. And 450mm length		

Correction Slip No. 1

(Guidelines for Earthwork in Railway Projects, July, 2003)

Para 9.0 of the ‘Guidelines for Earthwork in Railway Projects, July 2003’ stands modified as under:

- Para 9.1** - “ New Lines/Doubling/Gauge Conversion works are to be executed by Railways, as per Guidelines issued by RDSO. Railways should ensure proper quality control over earthwork. RDSO may be consulted for help in establishing proper testing facilities, training of supervisors and for any problem of formation encountered in the work.”
- Para 9.2** - Same as before
- Para 9.3** - Same as before
- Para 9.4** - “ All formation rehabilitation schemes need to be framed by railways themselves in consultation with respective GE cell on railways. It is the responsibility of executive authority to ensure that formation rehabilitation work is carried out in accordance with rehabilitation scheme and adequate control is exercised in execution. However, RDSO may be approached to provide consultancy on weak formation, if required.”
- Para 9.5** - “ Certification for quality of earthwork in formation in respect of New lines, Gauge Conversion and Doubling projects etc. will be done by Executive authority at SAG level (i.e. CE/Con of respective projects). CE/Con will submit details for certification of quality of earthwork to CRS as per RDSO check list titled as ‘Check List for Certification of Earthwork, June 2004.’”
